

KONISKA KUGGHJUL

Teknisk information

En konisk kuggväxel är en växel som har korsade axlar i sin förlängning. Detta erfordrar i de flesta fall en fri-bärande lagring. Därmed måste förhållandevis grova axlar användas. Lagring måste ske på bägge sidor av hjulet.

Dessutom krävs det dubbel lagring på drivaxeln. Alla koniska kugghjul får en axelkraft i riktning mot sitt nav. Därför måste lagret tåla att ta upp denna kraft. Vid inbyggnad måste måttet A beaktas extra noga. Vid felaktig inbyggnad sker en mycket snabb förslitning av hjulen och redan vid ett lågt varvtal uppstår en störande ljudnivå. Detsamma gäller när hjulen monteras med en felaktig vinkel.

Beteckningar

Dt, dt	=	Delningsdiameter
Da, da	=	Ytterdiameter
t	=	Delning
b	=	Kuggbredd
M	=	Modul för yttre kuggdelning
m	=	Modul för inre kuggdelning
Z, z	=	Kuggtal på stora respektive lilla hjulet
α, α^1	=	Delningscirkelns kuggvinkel
β, β^1	=	Kuggtoppens vinkel

Stora hjulet

$$Dt = Z \cdot M$$

$$\operatorname{tg} \alpha = \frac{Dt}{dt} \text{ eller } \frac{Z}{z}$$

$$\operatorname{tg} \beta = \frac{2 \cdot \sin \alpha}{Z}$$

$$Da = 2 \cdot M \cdot \cos \alpha + Dt$$

$$M = \frac{t}{\pi} \text{ eller } \frac{Dt}{Z}$$

$$m = \frac{Dt - b \cdot \sin \alpha}{Z}$$

Lilla hjulet

$$dt = z \cdot M$$

$$\operatorname{tg} \alpha^1 = \frac{dt}{Dt} \text{ eller } \frac{z}{Z}$$

$$\operatorname{tg} \beta^1 = \frac{2 \cdot \sin \alpha^1}{z}$$

$$da = 2 \cdot M \cos \alpha^1 + dt$$

$$M = \frac{t}{\pi} \text{ eller } \frac{dt}{z}$$

$$m = \frac{dt - b \cdot \sin \alpha^1}{z}$$

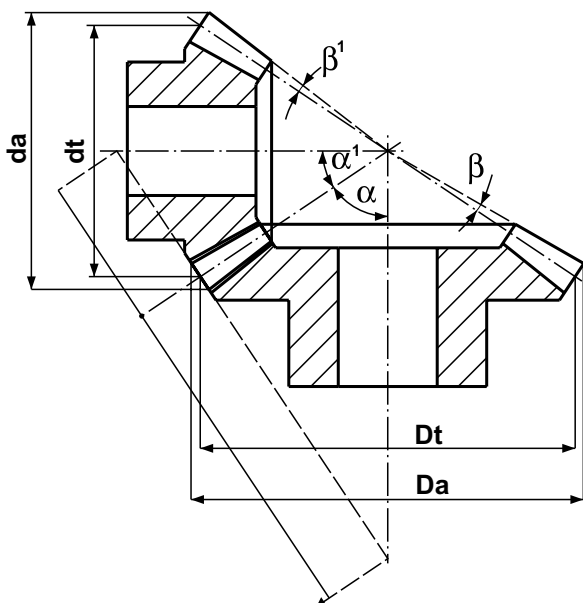

KORREKT INBYGGNADSMÅTT

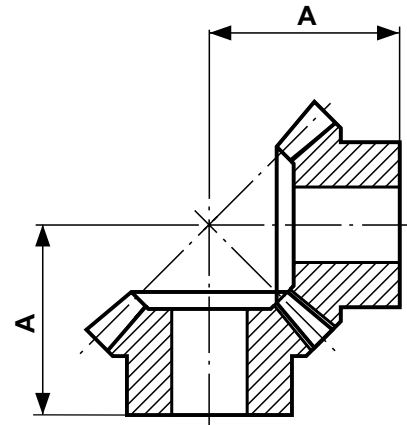

FÖR LITET INBYGGNADSMÅTT

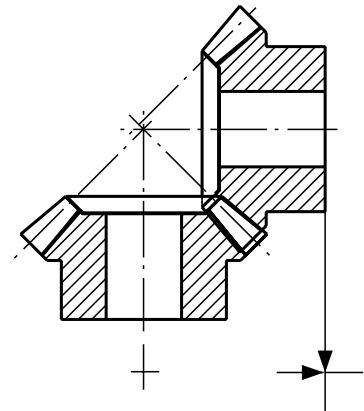

FÖR STORT INBYGGNADSMÅTT

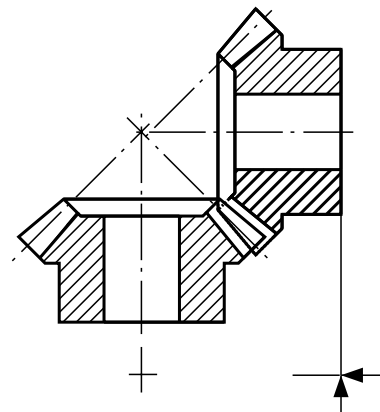

KONISKA KUGGHJUL

Utväxling 1:1 (=A)



Material

S = Stål SS EN 10083-1-34Cr4, kuggkvalitet 8f24

M = Mässing DIN 5170

Modul	Kugg	Artikelnr	Material	D	N	H	L	F	Z	A	d	Överförbar effekt (kW)		
												H7	100	500
0,5	40	A0540M40	M	20,7	12,0	5,0	8,5	9,5	3,0	17,05	4			
1,0	16	A1016M16-1	M	17,4	12,0	5,0	10,0	11,0	5,0	15,1	5			
	16	A1016S16	S	17,4	13,0	5,0	8,5	9,5	3,5	14,4	5			
	20	A1020M20-1	M	21,4	15,0	5,0	9,5	11,0	5,0	17,1	5			
	20	A1020S20	S	21,0	14,0	5,0	10,0	12,5	5,0	18,4	5			
	30	A1030M30	M	31,0	15,0	5,0	11,3	12,4	6,0	22,6	5			
1,5	30	A1030S30	S	31,0	15,0	5,0	11,3	12,4	6,0	22,6	5	0,01	0,04	0,43
	16	A1516S16	S	26,1	19,0	9,5	15,4	16,9	5,9	24,0	8	0,01	0,11	0,36
	19	A1519S19-1	S	30,6	20,3	12,0	-	21,3	7,0	30,0	8	0,01	0,05	0,16
	22	A1522S22-1	S	35,1	25,3	12,0	-	22,5	7,5	33,0	8	0,02	0,08	0,24
	26	A1526S26-1	S	41,1	28,3	12,0	-	23,2	8,5	36,0	8	0,03	0,16	0,47
2,0	30	A1530S30-1	S	47,1	30,3	12,0	-	27,2	10,0	42,0	12	0,04	0,21	0,63
	16	A2016S16	S	34,8	22,0	9,5	16,4	18,9	8,6	28,0	10	0,03	0,22	0,70
	19	A2019S19-1	S	40,8	25,3	12,0	-	24,2	9,0	36,0	8	0,03	0,14	0,44
	22	A2022S22-1	S	46,8	30,3	14,0	-	27,9	10,0	42,0	12	0,04	0,21	0,63
	26	A2026S26-1	S	54,8	35,3	14,0	-	31,4	12,0	48,0	12	0,06	0,31	0,94
2,5	30	A2030S30-1	S	62,8	40,3	17,0	-	34,1	13,0	54,0	14	0,10	0,52	1,58
	16	A2516S16	S	43,5	30,0	10,0	18,3	21,3	10,1	33,0	13	0,07	0,36	1,03
	19	A2519S19-1	S	51,0	35,3	13,0	-	27,1	11,0	42,0	12	0,15	0,26	0,80
	22	A2522S22-1	S	58,5	45,3	16,0	-	30,1	12,0	48,0	16	0,08	0,42	1,25
	26	A2526S26-1	S	68,5	45,3	16,0	-	33,2	15,0	54,0	16	0,14	0,68	2,04
3,0	30	A2530S30-1	S	78,5	50,3	20,0	-	39,0	16,0	64,0	16	0,21	1,05	3,15
	16	A3016S16	S	52,2	35,0	12,5	22,6	26,1	12,5	40,0	16	0,11	0,66	1,47
	19	A3019S19-1	S	61,2	40,3	17,0	-	36,0	13,0	54,0	14	0,10	0,52	1,55
	22	A3022S22-1	S	70,2	50,3	17,0	-	36,9	15,0	58,0	16	0,16	0,80	2,35
	30	A3030S30-1	S	94,2	60,3	22,0	-	43,8	19,0	74,0	20	0,37	1,80	5,50
3,5	16	A3516S16	S	60,9	40,0	15,0	26,6	30,1	13,2	47,0	19	0,14	0,84	2,28
	22	A3522S22-1	S	81,9	55,3	18,0	-	39,1	17,0	64,0	20	0,26	1,30	3,90
	30	A3530S30-1	S	110,0	70,3	22,0	43,0	47,1	23,0	82,0	20	0,63	3,14	9,40
4,0	16	A4016S16	S	69,7	45,0	17,5	30,3	35,3	16,4	54,0	22	0,29	1,43	3,31
	19	A4019S19-1	S	81,7	55,3	22,0	-	44,4	18,0	68,0	20	0,26	1,30	3,90
	22	A4022S22	S	93,7	60,3	22,0	-	45,9	20,0	74,0	25	0,42	2,20	6,30
	26	A4026S26-1	S	109,7	70,3	22,0	43,0	48,0	23,0	82,0	25	0,63	3,15	8,40
	30	A4030S30	S	125,7	80,3	25,0	49,0	54,2	26,0	94,0	25	0,94	4,70	14,10
4,5	16	A4516S16	S	78,4	50,0	19,5	34,7	40,2	18,7	61,0	25	0,36	1,76	4,41
	22	A4522S22	S	105,3	70,3	25,0	-	50,1	22,0	82,0	25	0,58	2,90	8,61
	30	A4530S30	S	141,4	80,3	28,0	54,0	60,0	29,0	105,0	30	1,55	7,80	23,50
5,0	16	A5016S16	S	87,1	54,0	21,0	37,6	43,6	19,3	67,0	27	0,44	2,50	5,70
	22	A5022S22	S	117,1	66,0	24,0	46,0	52,0	27,9	85,0	33	1,77	4,45	12,50
	30	A5030S30	S	157,1	80,0	28,0	57,0	63,0	37,8	109,0	40	1,91	7,65	23,50

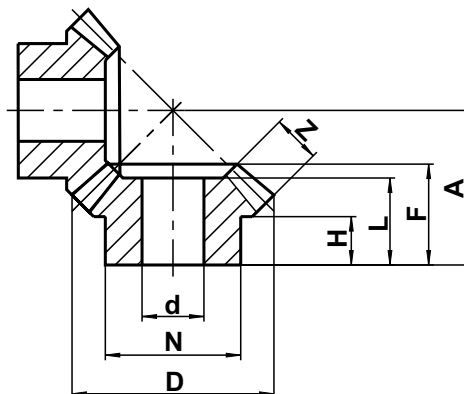

KONISKA KUGGHJUL

Utväxling 1:1,25 (=B)



Material

S = Stål SS EN 10083-1-34Cr4, kuggkvalitet 8f24



Modul	Kugg	Artikelnr	Material	D	N	H	L	F	Z	A	d	Överförbar effekt (kW)		
												H7	100	500
1,5	16	B1516S20	S	26,4	20	9,5	15	16,8	6,7	26	10	0,01	0,06	0,18
	20			31,9	24	10,4	16	19,0	6,7	26	12			
2,0	16	B2016S20	S	35,1	26	10,7	18	20,9	8,9	33	12	0,09	0,18	0,40
	20			42,5	28	13,0	20	23,6	8,9	33	14			
2,5	16	B2516S20	S	43,9	32	9,9	20	22,8	11,2	38	14	0,12	0,33	0,84
	20			53,1	34	14,0	23	26,3	11,2	38	16			
3,0	16	B3016S20	S	52,7	36	9,3	22	25,7	13,4	44	16	0,14	0,55	1,28
	20			63,8	40	16,0	26	29,9	13,4	44	18			
3,5	16	B3516S20	S	61,5	44	12,2	27	30,7	15,7	52	20	0,19	0,88	2,02
	20			74,4	48	19,0	31	35,5	15,7	52	22			
4,0	16	B4016S20	S	70,3	50	12,5	30	33,6	17,9	58	22	0,29	1,28	2,94
	20			85,0	52	21,0	34	39,2	17,9	58	24			
4,5	16	B4516S20	S	79,0	54	17,0	35	39,6	20,1	67	25	0,33	1,80	4,41
	20			95,6	58	24,0	40	45,9	20,1	67	27			
5,0	16	B5016S20	S	87,8	56	19,0	39	44,5	22,4	75	28	0,55	2,39	5,52
	20			106,2	60	28,0	45	51,5	22,4	75	30			

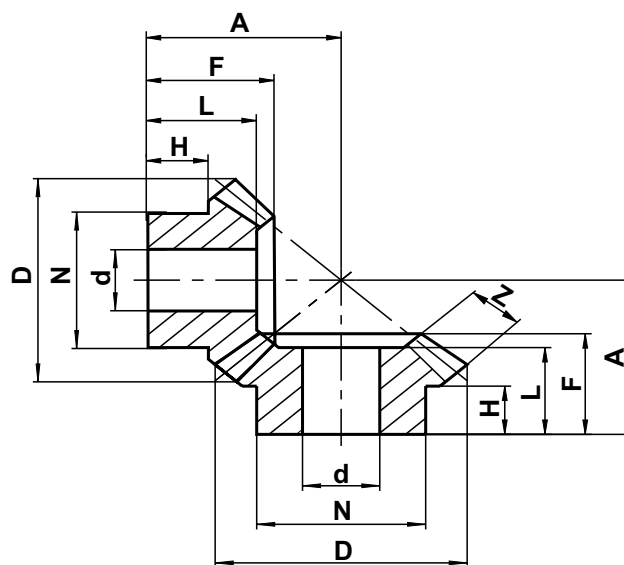

KONISKA KUGGHJUL

Utväxling 1:1,5 (=C)



Material

S = Stål SS EN 10083-1-34Cr4, kuggkvalitet 8f24

M = Mässing SS 5170

Modul	Kugg	Artikelnr	Material	D	N	H	L	F	Z	A	d H7	Överförbar effekt (kW)		
												100	500	1500
0,5	20	C0520M30	M	10,8	8,0	3,5	6,5	7,0	3,0	11,9	4			
	30			15,5	10,0	4,0	6,0	7,0	3,0	10,1	4			
1,0	16	C1016S24	S	18,1	13,3	7,0	-	12,0	4,3	20,0	4	0,01	0,02	0,05
	24			24,8	20,3	9,3	13,0	14,8	4,3	20,0	5			
1,5	16	C1516S24	S	26,5	18,0	10,0	17,8	18,8	7,6	30,0	8	0,06	0,14	0,25
	24			37,7	22,0	11,5	18,5	20,0	7,6	27,0	10			
2,0	16	C2016S24	S	35,3	22,0	10,0	19,1	21,1	10,1	36,0	11	0,14	0,29	0,58
	24			50,2	26,0	12,0	18,7	21,7	10,1	31,0	13			
2,5	16	C2516S24	S	44,1	28,0	10,5	21,9	24,4	12,6	43,0	14	0,17	0,40	1,10
	24			62,8	32,0	14,0	22,6	26,4	12,6	38,0	16			
3,0	16	C3016S24	S	53,0	34,0	11,0	24,7	27,7	15,1	50,0	17	0,21	0,84	1,80
	24			75,3	38,0	16,5	26,5	31,0	15,1	45,0	19			
3,5	16	C3516S24	S	61,8	40,0	12,5	28,5	32,0	17,7	58,0	20	0,29	1,21	2,79
	24			87,9	46,0	20,5	32,4	37,7	17,7	54,0	23			
4,0	16	C4016S24	S	70,6	46,0	14,0	32,2	36,2	20,2	66,0	23	0,36	1,69	4,08
	24			100,4	52,0	23,0	36,3	42,3	20,2	61,0	26			
4,5	16	C4516S24	S	79,4	50,0	16,5	37,0	41,5	22,7	75,0	25	0,44	2,35	5,55
	24			113,0	58,0	25,0	40,2	47,0	22,7	68,0	29			
5,0	16	C5016S24	S	88,3	56,0	17,5	39,8	44,8	25,5	82,0	28	0,66	3,20	7,36
	24			125,5	64,0	28,0	44,3	51,8	25,5	75,0	32			

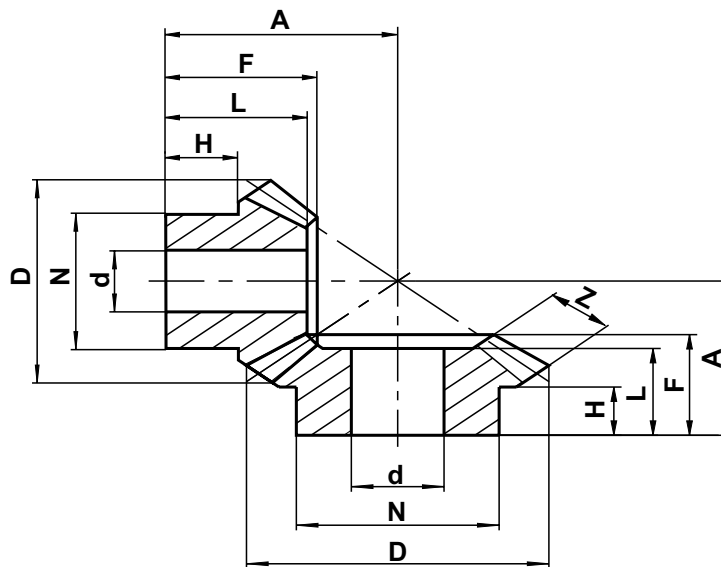

KONISKA KUGGHJUL

Utväxling 1:2 (=D)



Material

S = Stål SS EN 10083-1-34Cr4, kuggkvalitet 8f24

M = Mässing SS 5170

1

Modul	Kugg	Artikelnr	Material	D	N	H	L	F	Z	A	d	Överförbar effekt (kW)			
												H7	100	500	1500
1,0	15	D1015M30	M	16,50	12,0	5,0	10,0	12,0	6,0	21,5	5				
	30			31,00	16,0	6,0	10,0	13,0	6,0	17,2	5				
1,0	15	D1015S30-1	S	17,40	13,3	6,5	-	11,9	5,0	22,0	4	0,01	0,02	0,05	
	30			30,60	20,3	9,0	14,0	15,1	5,0	20,0	5				
1,5	15	D1515S30	S	25,20	18,0	10,4	18,8	19,8	8,8	34,0	8	0,07	0,14	0,33	
	30			46,30	24,0	12,0	17,6	19,6	8,8	26,0	11				
2,0	15	D2015S30	S	33,60	22,0	10,0	21,6	23,1	11,7	42,0	11	0,14	0,22	0,62	
	30			61,80	28,0	12,4	19,6	22,4	11,7	31,0	14				
2,5	15	D2515S30	S	41,90	28,0	11,2	25,5	27,3	14,7	51,0	14	0,18	0,47	1,21	
	30			77,20	36,0	15,8	24,8	28,3	14,7	39,0	18				
3,0	15	D3015S30	S	50,40	34,0	13,2	30,5	32,6	17,6	61,0	17	0,21	0,95	2,13	
	30			92,70	44,0	20,1	30,9	35,1	17,6	48,0	22				
3,5	15	D3515S30	S	58,80	40,0	14,4	34,4	36,9	20,5	70,0	20	0,33	1,32	3,12	
	30			108,00	50,0	22,5	35,1	40,0	20,5	55,0	25				
4,0	15	D4015S30	S	67,10	46,0	15,5	38,4	41,2	23,5	79,0	23	0,51	1,84	4,41	
	30			123,60	60,0	27,8	42,2	47,8	23,5	65,0	30				
4,5	15	D4515S30	S	75,50	52,0	16,7	42,2	45,4	26,4	88,0	26	0,58	2,57	6,10	
	30			139,00	68,0	31,1	47,4	53,7	26,4	73,0	34				
5,0	15	D5015S30	S	83,90	58,0	17,8	46,2	49,7	29,3	97,0	29	0,66	3,46	7,87	
	30			154,65	74,0	33,5	51,5	58,5	29,3	80,0	37				

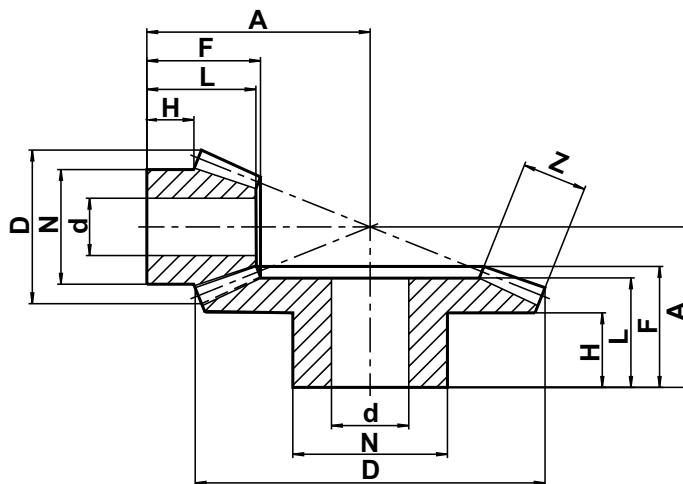

KONISKA KUGGHJUL

Utväxling 1:2,5 (=E)



Material

S = Stål SS EN 10083-1-34Cr4, kuggkvalitet 8f24

M = Mässing SS 5170

Modul	Kugg	Artikelnr	Material	D	N	H	L	F	Z	A	d	Överförbar effekt (kW)		
												H7	100	500
0,5	20	E0520M50	M	10,9	8,0	4,2	7,0	7,5	3,0	17,0	4,0			
	50			25,4	14,0	4,7	7,0	8,0	3,0	11,6	4,0			
1,0	16	E1016S40	S	18,6	13,3	7,4	-	14,4	6,5	28,0	4,0	0,01	0,02	0,06
	40			40,4	25,3	9,0	14,0	14,8	6,5	20,0	8,0			
1,5	16	E1516S40	S	26,8	20,0	11,3	22,0	22,9	11,3	42,0	10,0	0,08	0,18	1,50
	40			61,1	30,0	16,0	21,1	23,1	11,3	30,0	15,0			
2,0	16	E2016S40	S	35,7	26,0	12,7	27,3	28,4	15,1	54,0	12,0	0,14	0,36	0,40
	40			81,5	36,0	18,0	25,2	27,9	15,1	37,0	18,0			
2,5	16	E2516S40	S	44,6	32,0	14,4	32,7	34,1	18,9	66,0	16,0	0,18	0,62	0,80
	40			101,9	44,0	21,0	30,2	33,5	18,9	45,0	22,0			
3,0	16	E3016S40	S	53,6	40,0	16,4	38,1	39,7	22,6	78,0	20,0	0,21	1,14	1,61
	40			122,2	54,0	26,0	38,2	42,2	22,6	56,0	27,0			
3,5	16	E3516S40	S	62,5	46,0	17,0	42,4	44,3	26,4	89,0	22,0	0,40	1,80	2,76
	40			142,6	64,0	33,0	46,3	50,9	26,4	67,0	32,0			
4,0	16	E4016S40	S	71,4	52,0	18,6	47,9	50,0	30,2	101,0	26,0	0,58	2,53	4,04
	40			163,0	70,0	34,0	49,3	54,9	30,2	73,0	35,0			
4,5	16	E4516S40	S	80,4	60,0	20,6	53,2	55,6	33,9	113,0	30,0	0,73	3,46	5,70
	40			183,0	80,0	37,0	54,3	60,3	33,9	81,0	40,0			
5,0	16	E5016S40	S	89,3	66,0	21,2	57,6	60,3	37,7	124,0	32,0	0,92	4,56	7,94
	40			203,7	89,0	40,0	60,3	67,0	37,7	90,0	45,0			

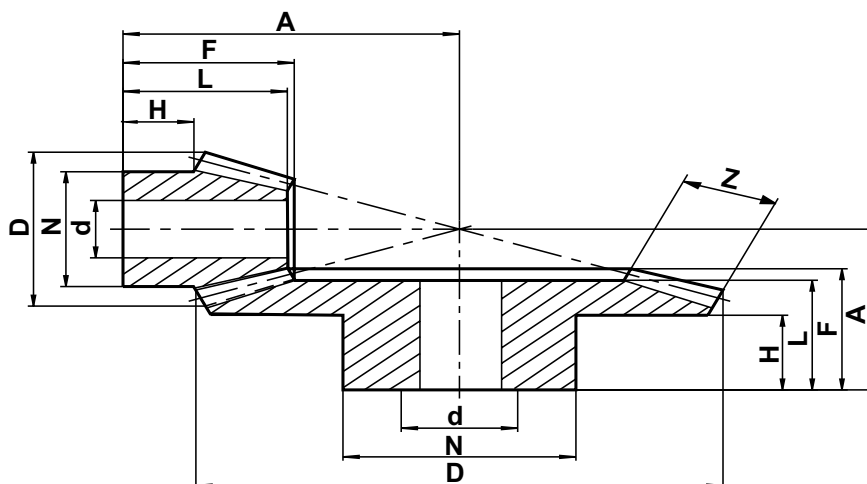

KONISKA KUGGHJUL

Utväxling 1:3 (=F)



Material

S = Stål SS EN 10083-1-34Cr4, kuggkvalitet 8f24

Modul	Kugg	Artikelnr	Material	D	N	H	L	F	Z	A	d	Överförbar effekt (kW)		
												H7	100	500
1,0	15	F1015S45	S	17,7	13,3	9,2	-	16,6	7,10	32,0	4	0,01	0,03	0,08
	45			45,3	25,3	10,0	15,0	17,1	7,10	22,0	8			
1,5	15	F1515S45	S	25,3	19,0	11,7	21,6	22,3	10,30	46,0	10	0,09	0,14	0,28
	45			68,4	30,0	15,0	20,8	23,0	10,30	30,0	15			
2,0	15	F2015S45	S	33,8	24,0	13,0	26,5	27,4	13,80	59,0	12	0,14	0,22	0,73
	45			91,3	34,0	20,0	26,9	29,7	13,80	39,0	17			
2,5	15	F2515S45	S	42,2	32,0	14,8	31,4	32,6	17,20	72,0	16	0,18	0,44	1,36
	45			114,1	48,0	26,0	34,8	38,3	17,20	50,0	24			
3,0	15	F3015S45	S	50,7	38,0	17,3	37,3	38,7	20,60	86,0	19	0,22	1,03	2,40
	45			136,9	56,0	30,0	40,7	45,0	20,60	59,0	28			
3,5	15	F3515S45	S	59,1	44,0	18,9	42,3	43,9	24,10	99,0	22	0,36	1,62	3,68
	45			159,7	65,0	35,0	47,8	52,7	24,10	69,0	32			
4,0	15	F4015S45	S	67,6	50,0	20,3	47,3	49,0	27,50	112,0	25	0,58	2,40	5,44
	45			182,5	72,0	39,0	52,9	58,4	27,50	77,0	36			
4,5	15	F4515S45	S	76,0	56,0	20,9	51,0	53,1	31,00	124,0	28	0,88	4,34	9,99
	45			205,3	80,0	43,0	58,7	65,0	31,00	86,0	40			
5,0	15	F5015S45	S	88,4	60,3	30,0	-	65,3	33,00	145,0	25	0,73	3,60	11,00
	45			226,9	90,3	40,0	59,0	66,7	33,00	92,0	30			

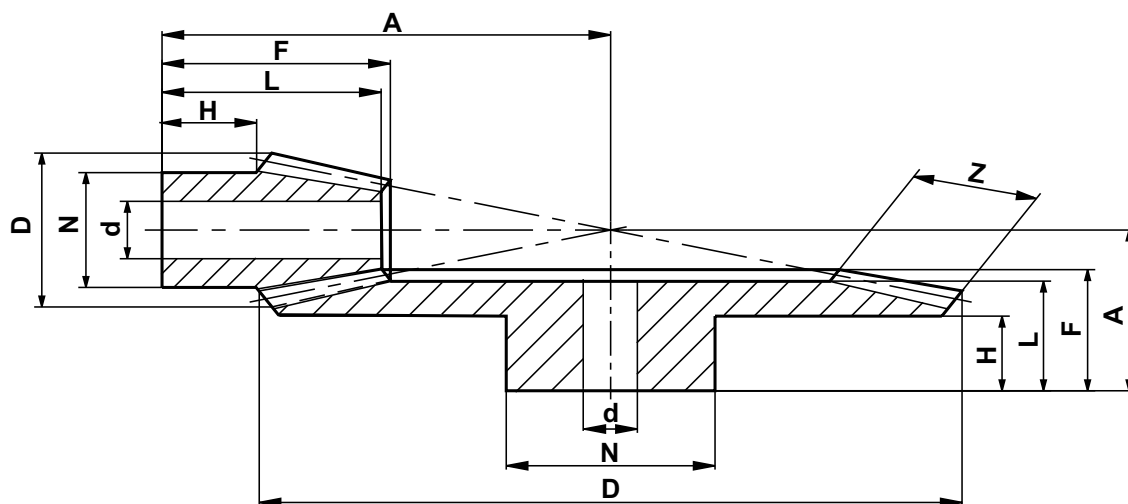

KONISKA KUGGHJUL

Utväxling 1:3,5 (=G)

Material

S = Stål SS EN 10083-1-34Cr4, kuggkvalitet 8f24



Modul	Kugg	Artikelnr	Material	D	N	H	L	F	Z	A	d	Överförbar effekt (kW)		
												H7	100	500
1,0	16	G1016S56	S	18,7	13,3	7,6	-	16,6	8,7	36	4	0,01	0,03	0,08
	56			56,3	30,3	10,0	15,0	16,7	8,7	22	8			
1,5	16	G1516S56	S	26,9	20,0	11,4	23,1	23,6	11,8	54	10	0,09	0,16	0,35
	56			84,8	32,0	18,0	23,0	25,3	11,8	33	16			
2,0	16	G2016S56	S	35,1	28,0	14,4	29,6	30,5	15,7	71	14	0,11	0,30	0,84
	56			113,1	42,0	23,0	29,6	32,7	15,7	43	21			
2,5	16	G2516S56	S	44,8	34,0	16,2	35,3	36,4	19,7	87	17	0,17	0,56	1,47
	56			141,4	52,0	29,0	36,2	40,2	19,7	53	26			
3,0	16	G3016S56	S	53,8	42,0	18,1	41,0	42,3	23,6	103	21	0,30	1,03	2,57
	56			169,6	64,0	36,0	45,0	49,6	23,6	65	32			
3,5	16	G3516S56	S	62,7	48,0	19,9	46,9	48,2	27,5	119	24	1,00	2,06	3,90
	56			197,9	72,0	39,0	49,5	55,1	27,5	73	36			
4,0	16	G4016S56	S	74,9	45,3	25,0	-	58,0	30,0	140	20	0,42	2,03	6,30
	56			225,3	90,3	35,0	52,0	59,7	30,0	82	30			

Utväxling 1:4 (=H)

Modul	Kugg	Artikelnr	Material	D	N	H	L	F	Z	A	d	Överförbar effekt (kW)		
												H7	100	500
1,0	15	H1015S60	S	17,8	13,3	7,7	-	17,2	9,3	38	4	0,01	0,03	0,08
	60			60,3	30,3	10,0	15,0	17,1	9,3	22	8			
1,5	15	H1515S60	S	25,4	20,0	11,7	21,5	22,2	10,2	57	10	0,09	0,17	0,40
	60			90,7	32,0	18,0	23,0	25,4	10,2	33	16			
2,0	15	H2015S60	S	33,9	24,0	12,3	25,6	26,6	13,6	73	12	0,15	0,33	0,84
	60			121,0	42,0	23,0	29,0	32,8	13,6	43	21			
2,5	15	H2515S60	S	42,4	30,0	14,1	30,9	32,0	17,0	90	15	0,22	0,66	1,73
	60			151,2	50,0	27,5	35,0	39,3	17,0	52	25			
3,0	15	H3015S60	S	50,8	36,0	15,9	36,0	37,3	20,4	107	18	0,30	1,00	2,57
	60			181,5	60,0	32,5	41,5	46,7	20,4	62	30			
3,5	15	H3515S60	S	59,3	44,0	18,9	42,2	43,7	23,8	125	22	0,40	1,70	4,01
	60			211,7	70,0	38,5	49,4	55,1	23,8	73	35			
4,0	15	H4015S60-1	S	71,1	50,3	23,0	-	55,1	30,0	145	20	0,37	1,83	5,50
	60			241,1	90,3	40,0	53,0	60,8	30,0	82	30			

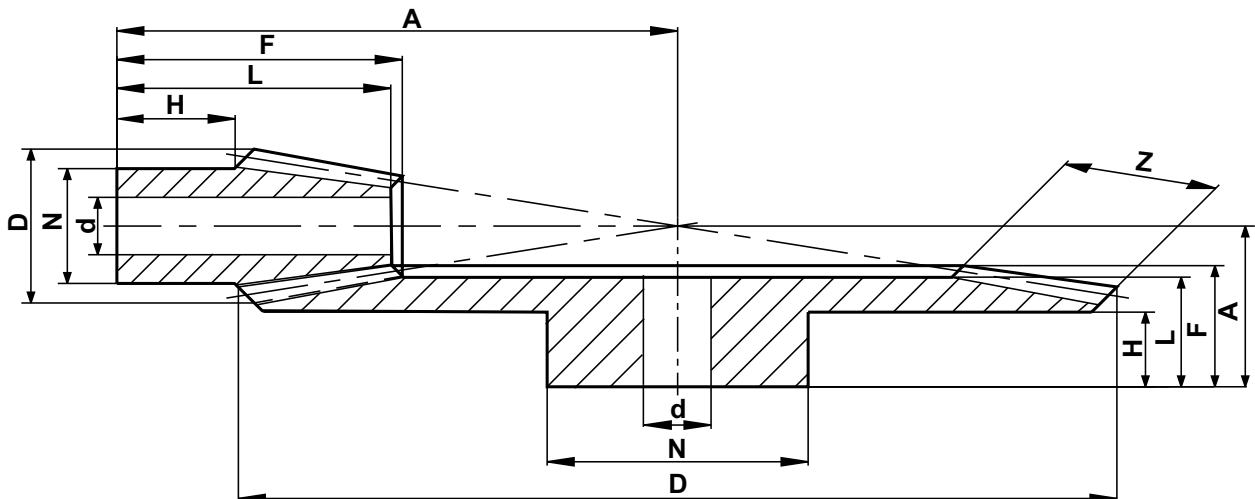

KONISKA KUGGHJUL

Utväxling 1:5 (=L)

Material

S = Stål SS EN 10083-1-C50E (1.1206), kuggkvalitet 8e25



Modul	Kugg	Artikelnr	Material	D	N	H	L	F	Z	A	d	Överförbar effekt (kW)		
												H7	100	500
1,0	15	L1015S75	S	17,8	13,3	8,3	-	20,0	11,5	46	4	0,01	0,03	0,08
	75			75,2	40,3	10,0	15	17,1	11,5	22	8			
1,5	15	L1515S75	S	26,7	20,3	15,0	-	27,8	12,0	72	8	0,01	0,07	0,20
	75			112,8	50,3	20,0	30	33,7	12,0	42	16			
2,0	15	L2015S75	S	35,7	25,3	19,0	-	35,1	16,0	94	8	0,03	0,16	0,47
	75			150,4	60,3	25,0	35	38,9	16,0	50	20			
2,5	15	L2515S75	S	44,6	30,3	21,0	-	41,4	20,0	115	12	0,07	0,37	1,10
	75			188,1	80,3	25,0	36	42,2	20,0	56	25			
3,0	15	L3015S75	S	53,5	35,3	25,0	-	49,7	24,0	138	14	0,14	0,68	2,04
	75			225,7	90,3	30,0	43	49,4	24,0	66	30			

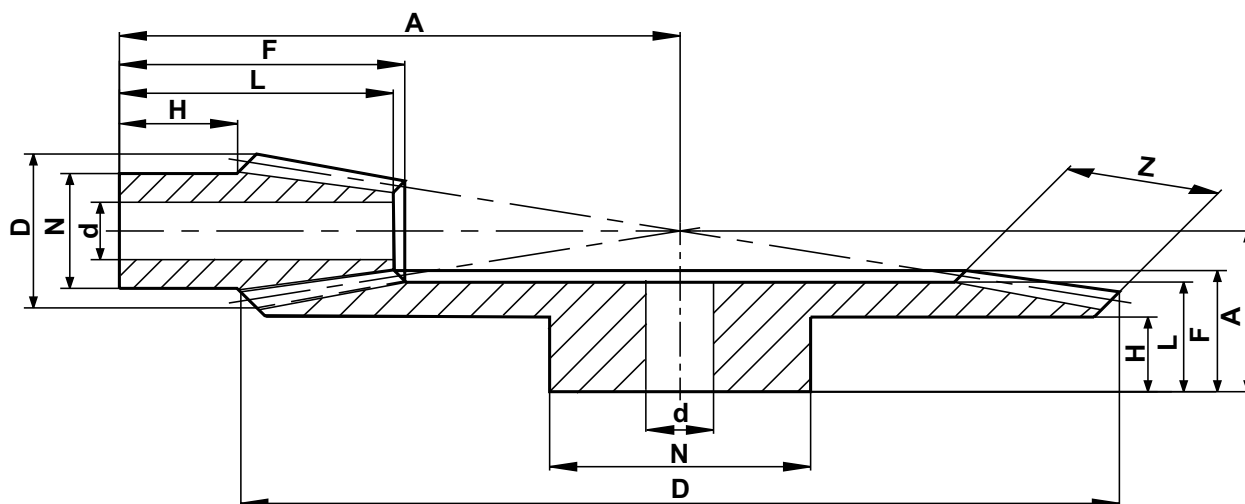

KONISKA KUGGHJUL

Formsprutade

Material

H = Hostaform C, kuggkvalitet 12



UTVÄXLING 1:1 (=A)											
Modul	Kugg	Artikelnr	D	N	H	L	F	Z	A	d H9	Vikt (g)
0,5	16	A0516H16	8,7	7,0	6,0	8,0	8,0	2,0	10,5	3	1
1,0	16	A1016H16	17,6	12,0	8,0	13,6	13,6	4,7	18,4	5	4
1,5	16	A1516H16	26,4	18,5	10,0	16,2	18,4	7,0	25,8	8	8
2,0	16	A2016H16	34,9	21,9	9,6	18,3	21,2	10,0	30,4	10	15
2,5	16	A2516H16	43,5	25,2	11,5	22,9	25,5	12,3	37,0	12	22
3,0	16	A3016H16	52,3	28,8	13,2	25,8	29,2	13,8	43,0	14	32
3,5	16	A3516H16	61,4	33,3	14,4	28,1	33,1	15,8	49,5	18	50

UTVÄXLING 1:2 (=D)											
Modul	Kugg	Artikelnr	D	N	H	L	F	Z	A	d H9	Vikt (g)
1,0	15	D1015H30	16,8	12,2	10,6	17,0	17,0	6,6	26,4	5	12
	30		31,1	18,0	9,1	14,8	16,2	6,6	20,9	8	
1,5	15	D1515H30	25,4	17,0	11,5	22,8	22,8	10,5	35,8	8	27
	30		46,4	23,4	9,6	17,5	19,5	10,5	26,2	10	
2,0	15	D2015H30	33,6	22,5	11,8	26,0	27,0	14,6	44,2	10	58
	30		62,2	30,2	11,8	22,6	24,2	14,6	32,6	12	
2,5	15	D2515H30	42,0	26,5	13,0	29,6	31,2	17,3	53,3	12	98
	30		77,3	36,1	15,0	27,5	29,5	17,3	40,5	16	
3,0	15	D3015H30	50,3	31,2	14,8	35,0	36,3	20,5	63,6	14	175
	30		93,0	45,0	19,0	34,2	37,0	20,5	49,5	18	

UTVÄXLING 1:3 (=F)											
Modul	Kugg	Artikelnr	D	N	H	L	F	Z	A	d H9	Vikt (g)
1,0	15	F1015H45	16,6	12,3	11,0	-	20,4	9,2	34,3	5	23
	45		46,1	23,4	9,6	16,5	18,2	9,2	22,7	10	
1,5	15	F1515H45	25,1	17,2	12,5	-	26,8	14,0	47,9	8	58
	45		68,8	30,4	11,5	21,5	23,0	14,0	29,4	12	
2,0	10	F2010H30	24,0	16,6	12,0	-	25,0	12,5	43,7	6	45
	30		61,7	30,3	11,5	20,2	22,5	12,5	28,0	12	
2,5	10	F2510H30	29,7	18,8	13,0	-	28,8	15,7	52,4	8	78
	30		77,2	36,1	15,5	25,2	29,0	15,7	35,7	18	

UTVÄXLING 1:4 (=H)											
Modul	Kugg	Artikelnr	D	N	H	L	F	Z	A	d H9	Vikt (g)
1,0	10	H1010H40	12,0	7,8	9,3	-	17,7	8,2	30,1	4	16
	40		40,8	23,4	10,8	15,7	17,0	8,2	20,1	10	
1,5	10	H1510H40	18,0	11,3	10,9	-	23,5	12,3	41,7	5	42
	40		61,2	30,4	12,8	20,0	21,7	12,3	26,2	12	
2,0	10	H2010H40	23,8	14,3	12,8	-	28,9	16,3	54,0	6	73
	40		81,5	36,0	16,6	24,7	27,0	16,3	32,5	18	

