



This data sheet interacts with

HDS2 Catalogue

14 to 15
18 to 21
& 49

No. 7 HDS2 Fixing of Slides and Bearing Elements

HDS2 slides and flat tracks are designed to accept the very high loads which can be applied when using bearing blocks and large bearings. In these cases it is important that the fixing screws used to attach the slides and flat tracks are securely fastened, and suitable cap head screws with a property class of 8.8 are used.

Details of required thread sizes, engagement depths, and tightening torques are given in the table below.

When size 25 slides and flat tracks are fitted using T-nuts then the M8 screw should have a sufficient thread length to ensure at least 8mm of engagement with the high tensile steel T-nut.

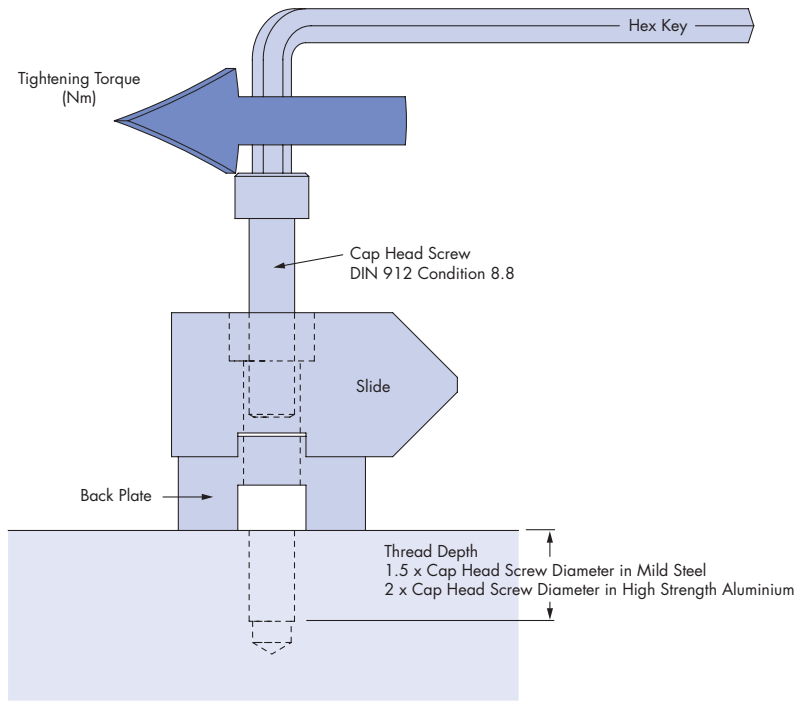

Part Number	Fixing Screw Size	Recommended Tightening Torque Nm	Minimum Tightening Torque Nm	Minimum Thread Depths	
				Mild Steel mm	High Strength Aluminium mm
.HSS25..	M8	25	20	12	16
.HTS25..	M8	25	20	12	16
.HSD25..	M8*	25	20	12	16
.HTD25..	M8*	25	20	12	16
.HSS33..	M12	85	65	18	24
.HTS33..	M12	85	65	18	24

* Low head cap screws DIN 7984 are required for .HSD25 & .HTD25. All other slide and flat track use standard cap head screw DIN912.

Hepco recommend that all fixing screw holes are used along the length of the slide and flat track, however in light duty applications it is possible to use alternative mounting holes, which save on installation costs.

HDS2 Fixing of Slide and Bearing Elements

Below are details of the recommended tightening torques for bearings and track rollers.

THJR... type
Bearings & Track Rollers

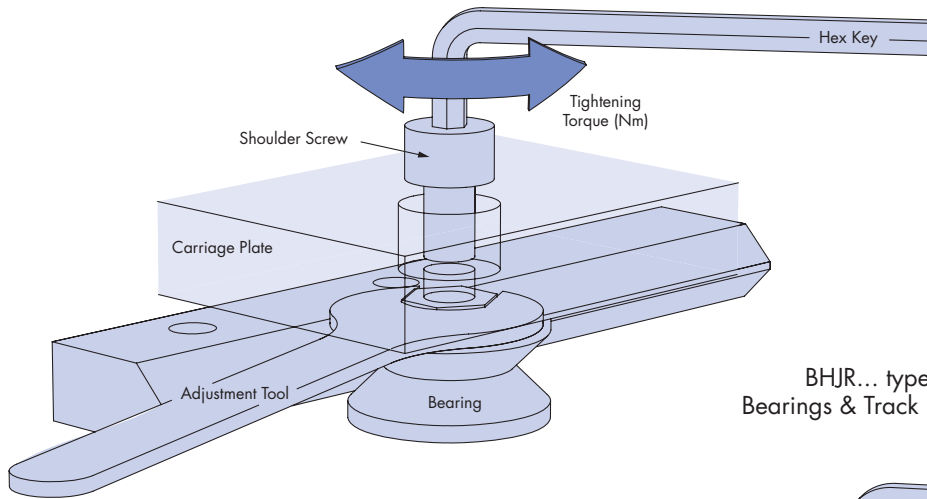

BHJR... type
Bearings & Track Rollers

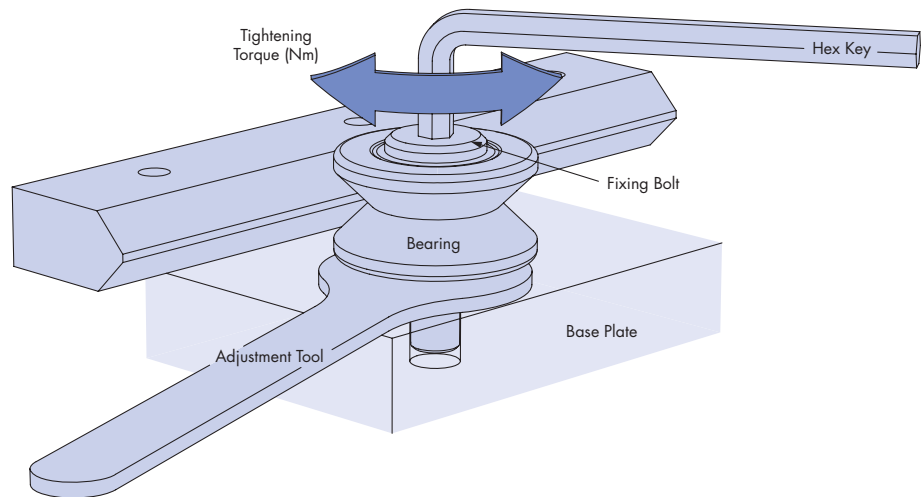

	Bearing & Track Roller Part Number							
	THJR64 THRR58	THJR95 THRR89	THJR120/128 THRR122	THJR150 THRR144	BHJR64 BHRR58	BHJR95 BHRR89	BHJR120/128 BHRR122	BHJR150 BHRR144
Tightening Torque Nm	80 Nm	180 Nm	500 Nm	750 Nm	45 Nm	180 Nm	500 Nm	750 Nm
Hex Key Size	8 mm	10 mm	14 mm	22 mm	10 mm	12 mm	14 mm	19 mm
Adjustment Tool	AT 54	AT 95	AT 128	AT 150	AT 54	AT 95	AT 128	AT 150

HepcoMotion®, Lower Moor Business Park,
Tiverton Way, Tiverton, Devon, England EX16 6TG

Tel: +44 (0) 1884 257000

Fax: +44 (0) 1884 243500

E-mail: sales@hepcotion.com



INVESTOR IN PEOPLE

