



This data sheet interacts with	
HDS2 Catalogue	
	16 -17 25 & 39

## No. 4 HDS2 Bearing Blocks

Hepco HDS2 bearing blocks can be used in place of V bearings in cases where limited width is available and where high rigidity is required. They are designed for use in conjunction with the .HSS25 V slides only. They may be used with the HB25C and HB25 construction beams with slides corner mounted in any position, 24 HDS2 catalogue. They may also be used in conjunction with high style back plates HHN25 and HHW25, 16&17 HDS2 catalogue, either mounted to a base or, T-slot mounted to the beams, 25 HDS2 catalogue.

Bearing blocks feature high capacity full complement needle roller races within a precision machined rigid casting. A lubrication facility channels lubricant directly to the needle races then onto the roller/slide contact faces. Side and adjustable end seals retain the lubricant and prevent ingress of debris. Bearing blocks can be mounted via high tensile steel concentric and eccentric (adjustable) bolts or, by using the optional tapped hole facility in the back face. Blocks are available in high quality nodular cast iron, high strength aluminium, and stainless steel.

There are many different combinations to choose from when using the HDS2 bearing blocks in conjunction with the construction beams, and back plates. To demonstrate the versatility and flexibility of the system some of the more popular configurations are shown below.

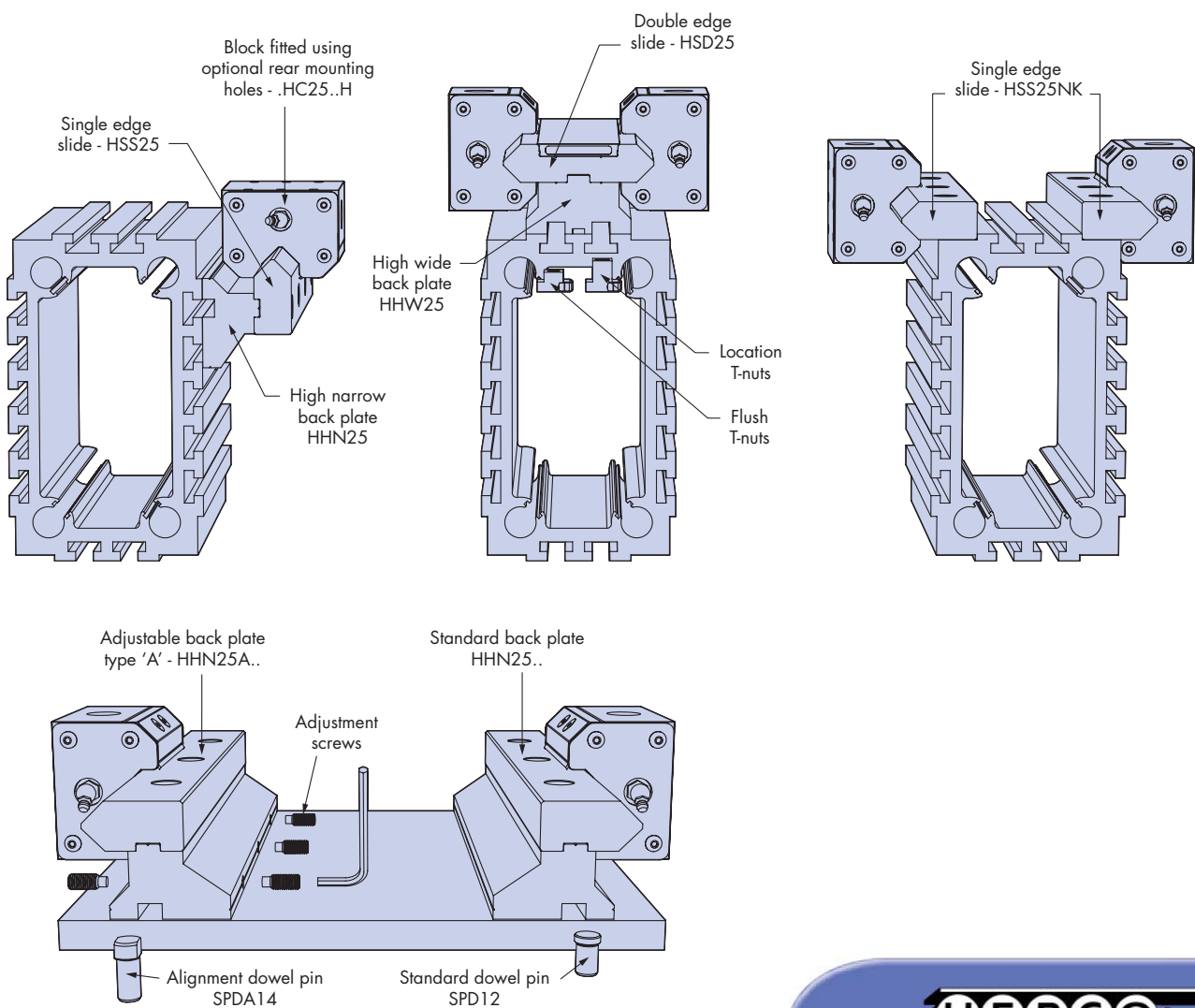

# No. 4 HDS2 Bearing Blocks

## Machine Bed Application

This example shows a vertically inclined precision ground single edge V slide one side and a ground narrow flat track the other. The high load capacity bearing blocks have maximum capacity in the vertical plane due to 4 roller bearings per block sharing the load. The back face tapped hole mounting option is used for maximum rigidity in the application.

Eccentric type track rollers are used in conjunction with the flat track for individual adjustment to ensure that the load is shared equally by all rollers.

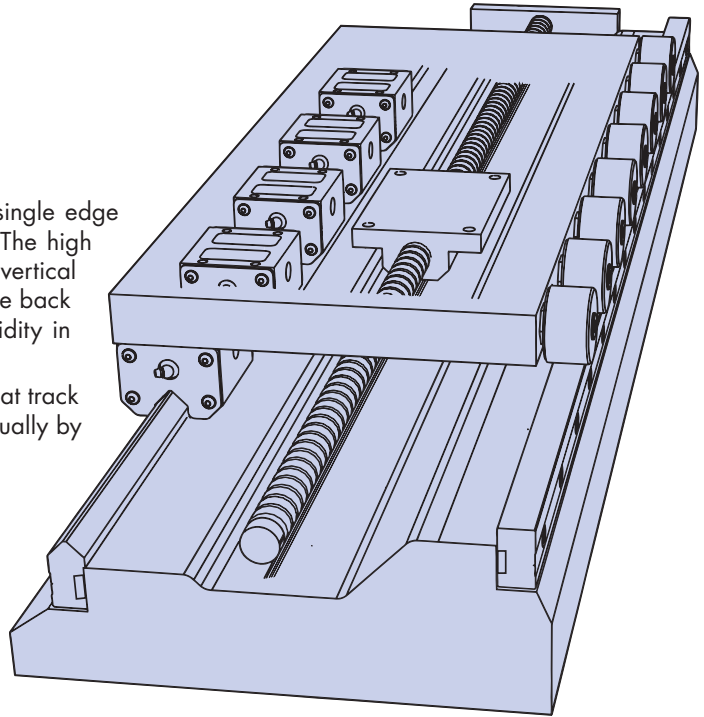

## Details & Dimensions of Steel and Aluminium Bearing Blocks

**IMPORTANT:** Lubrication channels are not interconnected. Both ends must be charged with grease.

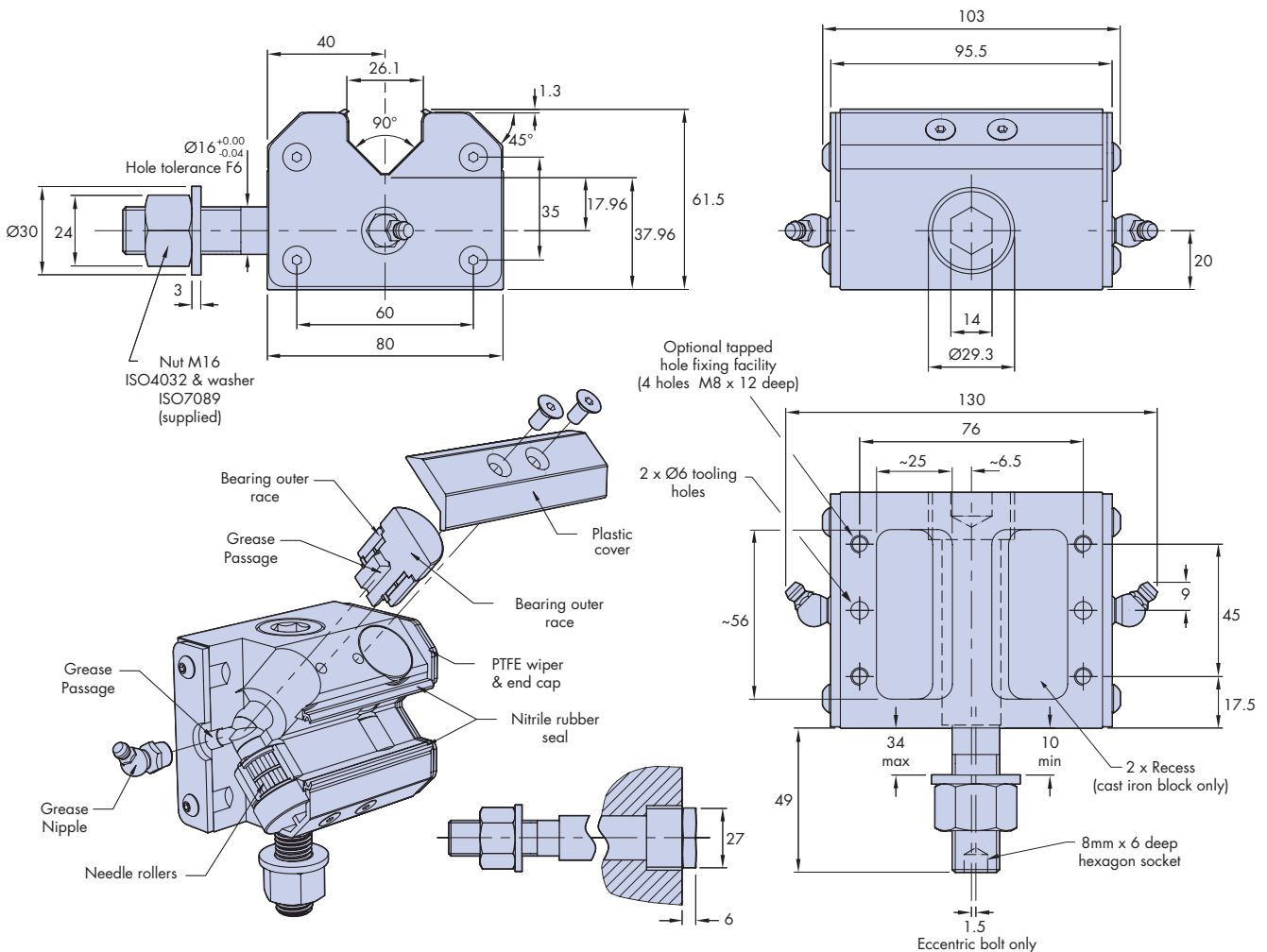

# No. 4 HDS2 Bearing Blocks

## Details & Dimensions of Stainless Steel Bearing Blocks - PHC25SS.

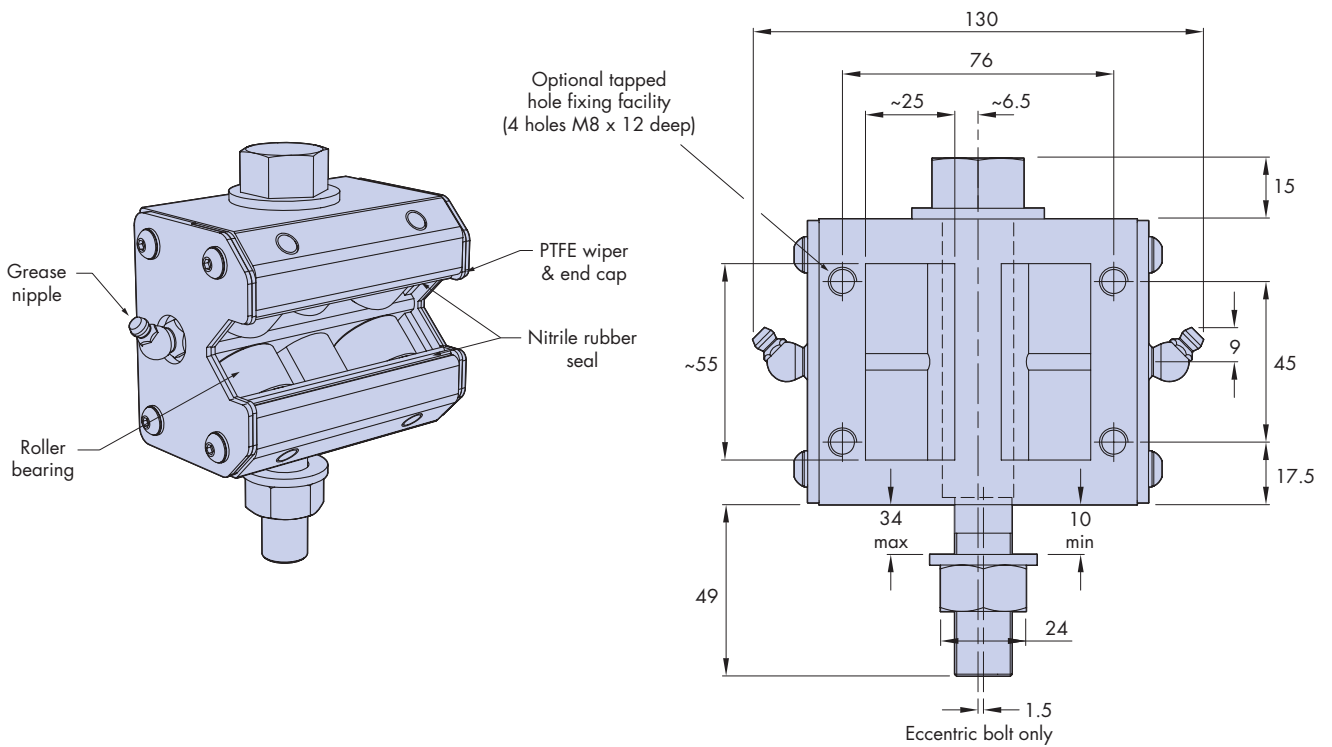
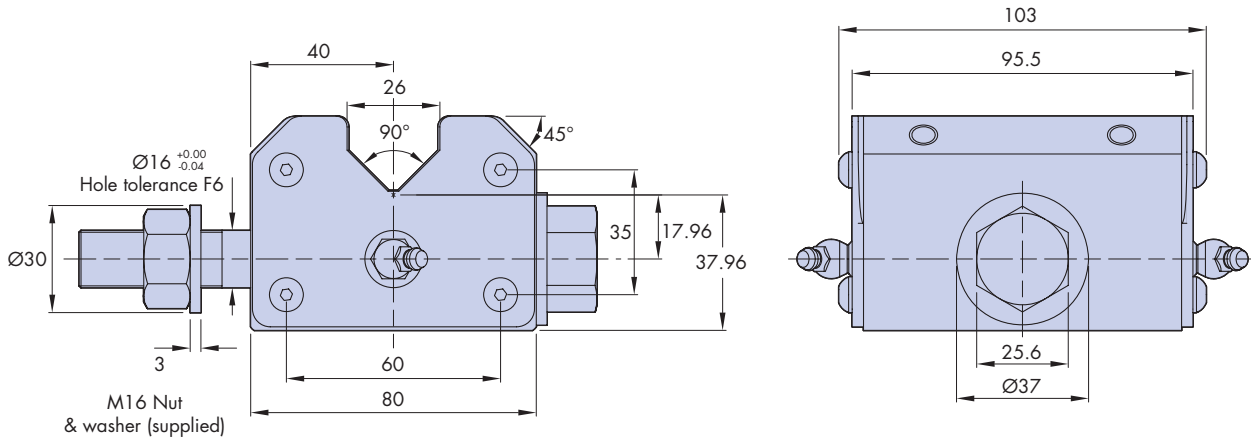

# No. 4 HDS2 Bearing Blocks

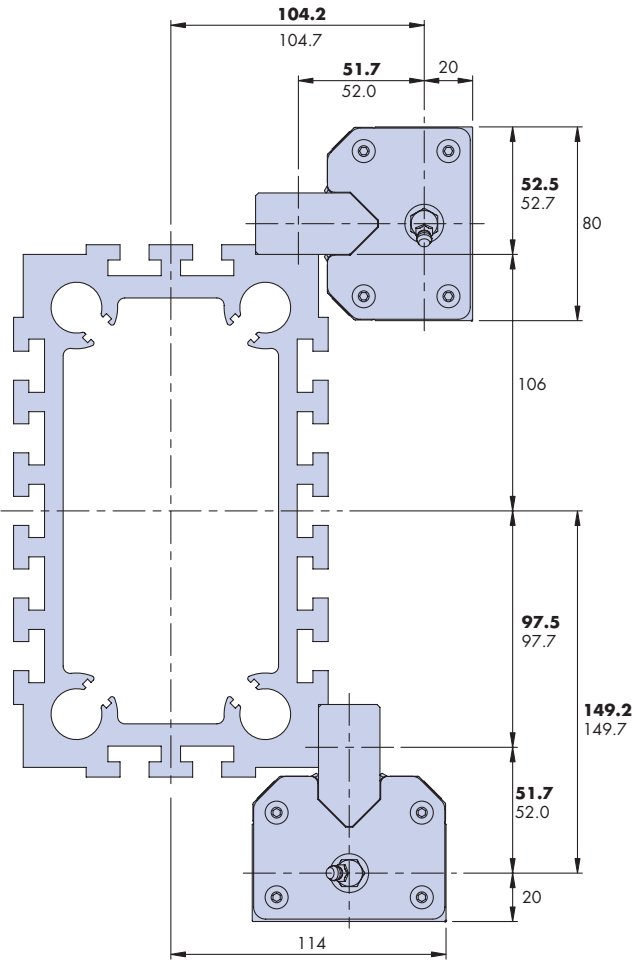

The drawings on this page illustrate various important dimensions when using HDS2 bearing blocks. Additional dimensions can be determined by working from the bearing block dimensions shown in this datasheet as well as component dimensions shown in the full HDS2 catalogue.

**Important dimensions for bearing block assemblies are shown in bold for precision ground (PHSS25..) slide and in standard text below in respect of commercial grade (CHSS25..).**

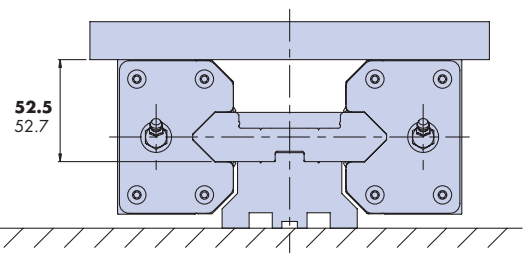
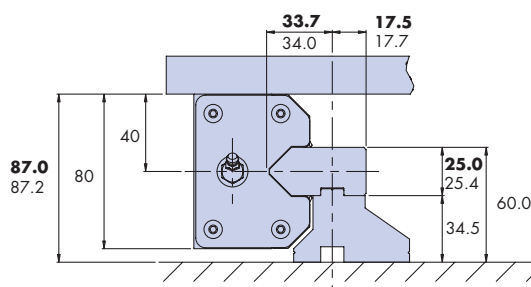
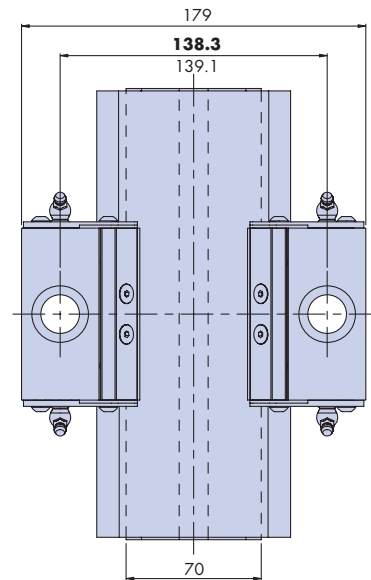
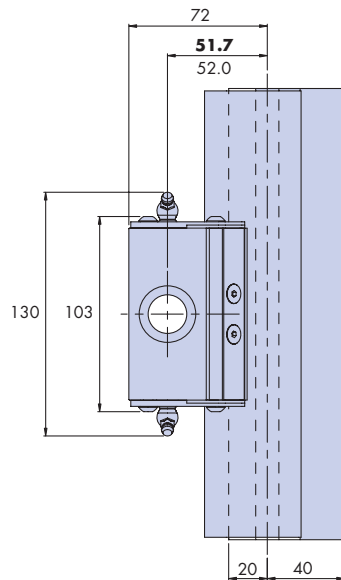

# No. 4 HDS2 Bearing Blocks

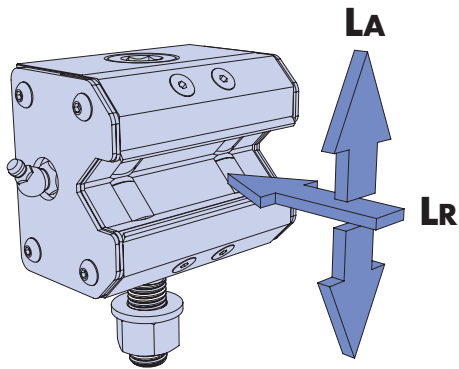

Part Number	Maximum Load Capacities	
	Axial Load LA	Radial Load LR
P/CHC25A.	10 000 N	20 000 N
P/CHC25S.	10 000 N	20 000 N
PHC25SS.	7 500 N	15 000 N

The life of a system will be dictated by the component which fails first. In systems which are properly lubricated, the slides will normally last longer than the bearing blocks, therefore these will be the life determining factor for the system.

The load on each bearing block can be calculated using conventional statics methods. Knowledge of these loads allows the load factor Lf for each bearing block to be calculated according to the equation below.

$$\text{Load Factor } L_f = \frac{L_A}{L_{A(\max)}} + \frac{L_R}{L_{R(\max)}}$$

Once the load factor has been calculated, it is used to determine the life of the bearing block by reading the life from the nomogram below.

When bearing blocks are run on commercial slides, the maximum load factor is less since the coarser finish prevents the highest loads from being accepted satisfactorily, therefore, **the maximum load factor for bearing blocks running on commercial slides is 0.7.**

The aluminium block is less strong than the cast iron version. This limits the peak load which it can carry without affecting the life at lower loads, therefore, **the maximum load factor for aluminium blocks is 0.7.**

To obtain good performance from the bearing blocks, it is necessary that they are adequately lubricated, the bearings should be regularly greased via the nipples provided, and a lubricant film be present on the V slide faces.

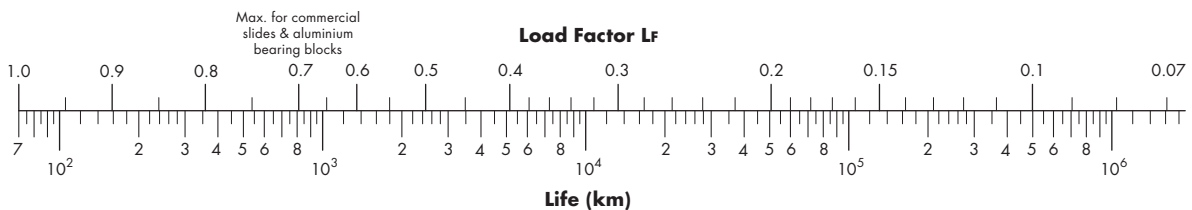

# No. 4 HDS2 Bearing Blocks

## Example

A machine uses a PHSD25 double edge V slide and 4 PHC25 bearing blocks to support a 5000N load which is offset 500mm from the system centre as illustrated. The system moves at 0.4m/s for 40 hours per week on a 30% duty cycle. The loads on the bearing blocks are determined as follows:

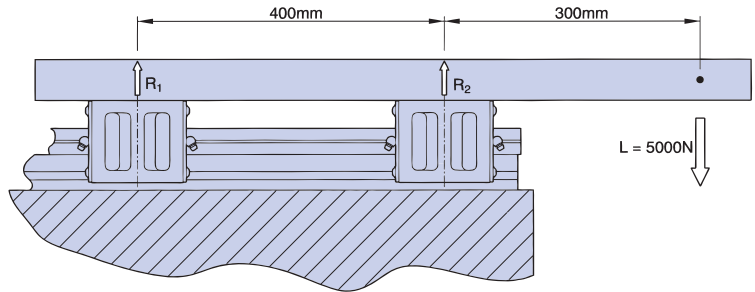

[summing all forces]

$$R_1 + R_2 = L = 5000N$$

[taking moments about left block centre line]

$$R_2 \times 0.4m - 5000N \times 0.7m = 0$$

[re-arranging above]

$$R_2 = (5000N \times 0.7m) / 0.4m = 8750N$$

[substituting in first equation]

$$R_1 + 8750N = 5000N \text{ therefore } R_1 = -3750N$$

Both R1 and R2 are supported by two bearing blocks, so each block experiences half the load. The most heavily loaded block therefore experiences a load of  $8750/2 = 4375N$

$$\text{Load factor } L_f \text{ for bearing blocks} = \frac{L_A}{L_{A(\max)}} + \frac{L_R}{L_{R(\max)}} = \frac{4375}{10\,000} + \frac{0}{20\,000} = 0.438$$

Referring to the nomogram above a load factor of 0.438 corresponds to a life of about 3800km. In this application the system travels  $0.4m/s \times 60 \times 60 \times 40$  (seconds/week)  $\times 0.3$  (30% duty cycle) = 17280m or 17.3km per week. 3800km therefore equates to 220 weeks or **4.2 years life**.

**HepcoMotion**<sup>®</sup>, Lower Moor Business Park,  
Tiverton Way, Tiverton, Devon, England EX16 6TG

**Tel: +44 (0) 1884 257000**

**Fax: +44 (0) 1884 243500**

**E-mail: sales@hepcotion.com**



INVESTOR IN PEOPLE



**HEPCO**<sup>®</sup>  
[www.HepcoMotion.com](http://www.HepcoMotion.com)