



This data sheet interacts with
HDS2 Catalogue
 42 to 44

No. 5 HDS2 Load Life Calculations + Examples

The load capacity and life expectancy of Hepco HDS2 will be determined by several factors. The key factors are the size and type of bearings and slide, the presence or absence of lubrication and the magnitude and direction of loads. Other factors including operational speed, length of stroke and environmental conditions may also have an effect.

When calculating the system load and life, one of two approaches should be taken: if the system uses a conventional 4 bearing carriage (such as any of the Hepco HDS2 carriages), then this may be treated as a single item, and the load and life be determined as in the **Systems with carriages** section below; alternatively, each bearing can be treated separately according to the method shown in the **Individual bearing calculations** section.

Systems with Carriages

When calculating the loading and life of a V slide system using a 4 bearing carriage, the loading on the system should be resolved into the direct load components, L_1 and L_2 , and the moment loading components M , M_v and M_s (see diagram on the right).

The maximum direct and moment load capacities for HDS2 carriages are given in the tables below. Capacities are included for both 'dry' and 'lubricated' conditions - this refers to the 'V' contact, since all bearings are greased internally for life. Values are based on shock free duty.

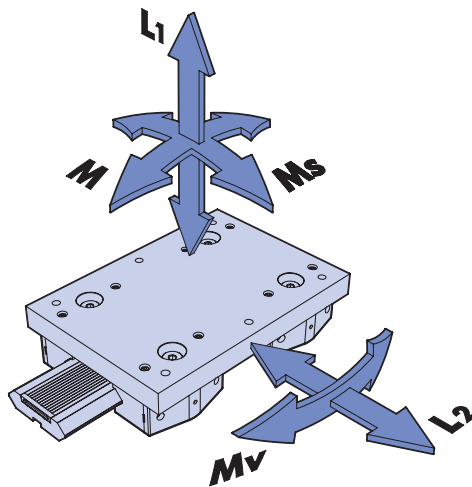

Carriage Part Number	Dry System					Lubricated System				
	L1(max)	L2(max)	Ms(max)	Mv(max)	M(max)	L1(max)	L2(max)	Ms(max)	Mv(max)	M(max)
	N	N	Nm	Nm	Nm	N	N	Nm	Nm	Nm
AU6425D..	10 000	16 000	450	8 x D	5 x D	10 000	16 000	450	8 x D	5 x D
AU..6425C..	10 000	16 000	900	8 x D	5 x D	10 000	16 000	900	8 x D	5 x D
AU..6425N..	10 000	16 000	810	8 x D	5 x D	10 000	16 000	810	8 x D	5 x D
AU..6425W..	10 000	16 000	1260	8 x D	5 x D	10 000	16 000	1260	8 x D	5 x D
AU9525D..	28 000	40 000	1280	20 x D	14 x D	28 000	40 000	1280	20 x D	14 x D
AU..9525C..	28 000	40 000	2510	20 x D	14 x D	28 000	40 000	2510	20 x D	14 x D
AU..9525N..	28 000	40 000	2260	20 x D	14 x D	28 000	40 000	2260	20 x D	14 x D
AU..9525W..	28 000	40 000	3520	20 x D	14 x D	28 000	40 000	3520	20 x D	14 x D
AU12025D..	-	-	-	-	-	40 000	60 000	1830	30 x D	20 x D
AU..12025C..	-	-	-	-	-	40 000	60 000	3590	30 x D	20 x D
AU..12025N..	-	-	-	-	-	40 000	60 000	3230	30 x D	20 x D
AU..12025W..	-	-	-	-	-	40 000	60 000	5030	30 x D	20 x D
AU..12833N..	40 000	60 000	4530	30 x D	20 x D	40 000	60 000	4530	30 x D	20 x D
AU..12833W..	40 000	60 000	6530	30 x D	20 x D	40 000	60 000	6530	30 x D	20 x D
AU..15033N..	-	-	-	-	-	68 000	100 000	7710	50 x D	34 x D
AU..15033W..	-	-	-	-	-	68 000	100 000	11 110	50 x D	34 x D

Load capacities apply to steel systems, for stainless steel systems load capacities are 25% lower

No. 5 HDS2 Load Life Calculations + Examples

Calculating the System Load Factor

To calculate the system life, the load factor LF should first be calculated using the equation below. Where Mv and M loads are concerned, the $M_{v(max)}$ and $M_{(max)}$ for the relevant carriage will need to be determined. This is established by multiplying the figure shown in the table by the spacing of the bearing, D, in millimetres. LF should not exceed 1 for any combination of loads. Once LF has been determined for the application, the life is calculated as shown on 43 of the full HDS2 catalogue.

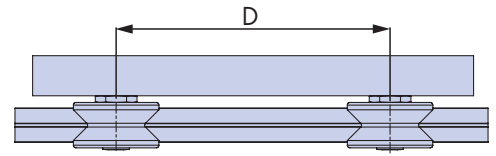

$$\text{Load Factor LF} = \frac{L1}{L1_{(max)}} + \frac{L2}{L2_{(max)}} + \frac{Ms}{Ms_{(max)}} + \frac{Mv}{Mv_{(max)}} + \frac{M}{M_{(max)}}$$

Individual 'V' Bearing Calculations

Many systems do not use standard carriages. In such cases it is necessary to use conventional statics calculations to determine the loading on each bearing in the system, by resolving into axial LA and radial LR components. Maximum capacities for all types of Hepco HDS2 'V' bearings are given in the table below, and are included for both 'dry' and 'lubricated' conditions - this refers to the 'V' contact, since all bearings are greased internally for life. Values are based on shock-free duty.

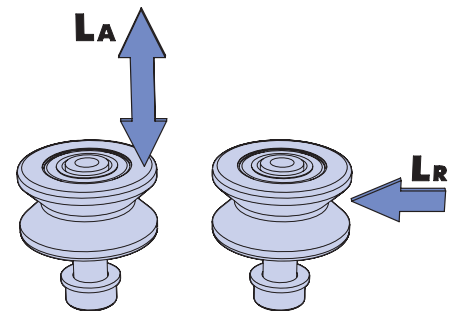

Bearing Part Number	Dry			Lubricated		
	LA (max)	LR (max)	Basic Life	LA (max)	LR (max)	Basic Life
	N	N	(km)	N	N	(km)
..HJ64	2500	8000	300	2500	8000	500
..HJ95	7000	20 000	400	7000	20 000	400
..HJ120	-	-	-	10 000	30 000	700
..HJ128	10 000	30 000	500	10 000	30 000	700
..HJ150	-	-	-	17 000	50 000	2000

The above figures assume that bearings are used with slides equal or larger than the preferred slide selection for that bearing size. For details of the preferred sizes, 18-19 of the HDS2 catalogue. For loading of bearings with smaller slides, please contact Hepco.

Calculating the System Load Factor

To calculate the system life, the load factor LF should first be calculated using the equation below.

$$\text{Load Factor LF} = \frac{LA}{LA_{(max)}} + \frac{LR}{LR_{(max)}}$$

LF should not exceed 1 for any combination of loads.

Once LF has been determined for each bearing, the life can be calculated as follows:

Calculating System Life

With the LF determined for either a 4 bearing carriage or for an individual bearing, the life in km can be calculated using one of the three equations below. In these equations, the Basic Life is taken from the table (above) in respect of the bearing and lubrication condition applicable.

No. 5 HDS2 Load Life Calculations + Examples

Dry System

$$\text{Life (km)} = \frac{\text{Basic Life}}{(0.04 + 0.96L_f)^2}$$

$$\text{Life (km)} = \frac{\text{Basic Life}}{(0.04 + 0.96L_f)^3}$$

(Use this calculation for all bearings other than ..HJR150.)

Lubricated System

$$\text{Life (km)} = \frac{\text{Basic Life}}{(0.04 + 0.96L_f)^{3.3}}$$

(Use this calculation for ..HJR150. bearings only.)

Notes:

1. The maximum values of L₁, L₂, M_s, M, M_v, L_A and L_R, and the magnitude of the system basic life for each bearing type, relate to the performance of complete systems. Tests have shown these figures to be more reliable than working from theoretical static and dynamic load capacities (C and C₀) of the bearings.
2. The calculations within this section assume that the linear stroke involves a number of complete bearing revolutions. If the stroke of any application is less than five times the bearing outside diameter, then please calculate the distance travelled as if it moves five bearing diameters per stroke. Systems operating at speed in excess of 8m/s may require additional calculations. Please contact Hepco for assistance.
3. For the purpose of the Load/Life calculations on this page, the axial load L_A is the load in the axial direction which the bearing can accept from a 'V' slide engaged in its outer ring. Since the line of force is some distance removed from the axis of the bearing, this value is much less than the theoretical axial load capacity of the bearing.
4. In the above calculations, the term lubricated refers to the contact between the slide and bearing 'V's. This lubrication may best be achieved using Hepco lubricators or cap wipers, however other methods which ensure the presence of a suitable grease or oil in the critical area are acceptable.
5. When a system consists of more than 4 bearings per carriage (e.g. see application example on 9) it cannot always be guaranteed that the load will share equally between all bearings. In such cases it is recommended that the system be derated to allow for the life of the most heavily laden bearing. Please contact Hepco for assistance.

Track Roller Calculations

Systems incorporating track rollers running on flat tracks or flat faces of the single edge 'V' slides will require a different calculation to determine the load and life. Track rollers only have a radial load capacity stated as they are not usually loaded axially. Their pure rolling contact with the track means that they do not need to be derated for use in unlubricated applications (although it is recommended that the tracks and rollers be lightly oiled for best performance). The maximum radial load capacity L_R for the Hepco HDS2 track Roller is stated in the table below.

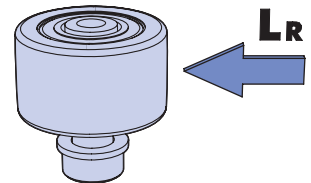

Load Capacities for Track Rollers		Basic Life (km)
Roller Part Number	L _R (max)	
		N
..HRN58	5 000	500
..HRR58	10 000	300
..HRR89	20 000	400
..HRR122	30 000	700
..HRR144	80 000	500

Calculating the System Load Factor

To calculate the roller life, the load factor L_F should first be calculated using the equation below.

$$\text{Load Factor } L_f = \frac{L_R}{L_{R(\max)}} \quad L_f \text{ should not exceed } 1.$$

Calculating Track Roller Life

With L_F determined for each roller, the life in km can be calculated using the equation below. The basic life is taken from the table (above) for the respective track roller.

$$\text{Life (km)} = \frac{\text{Basic Life}}{L_f^3}$$

(Use this calculation for all track rollers other than ..HRR144.)

$$\text{Life (km)} = \frac{\text{Basic Life}}{L_f^{3.3}}$$

(Use this calculation for ..HRR144. track roller only.)

No. 5 HDS2 Load Life Calculations + Examples

Example 1

A machine incorporates a heavy cast component mounted to a Hepco AU9525WCW carriage (Assembled carriage with fitted cap wipers 26-27 of the full HDS2 catalogue) fitted to a HB25 beam assembly with CHSS25NK slides. The weight of the cast component and carriage assembly is 500kg, and the centre of mass is central along the length of the carriage, and 150mm from the slide V as shown in the diagram.

The system moves at 0.4m/s on a 50% duty cycle for 40 hours per week. The load factor can be determined using the calculation below.

$$\text{Load Factor } L_f = \frac{L_1}{L_{1(\max)}} + \frac{L_2}{L_{2(\max)}} + \frac{M_s}{M_{s(\max)}} + \frac{M_v}{M_{v(\max)}} + \frac{M}{M_{(\max)}}$$

$$L_1 = M = M_v = 0$$

$$L_2 = 500\text{kg} \times 9.81\text{m/s}^2 \text{ (gravity)} = 4905\text{N}$$

$$M_s = 4905\text{N} \times 0.15\text{m} = 735.75\text{Nm}$$

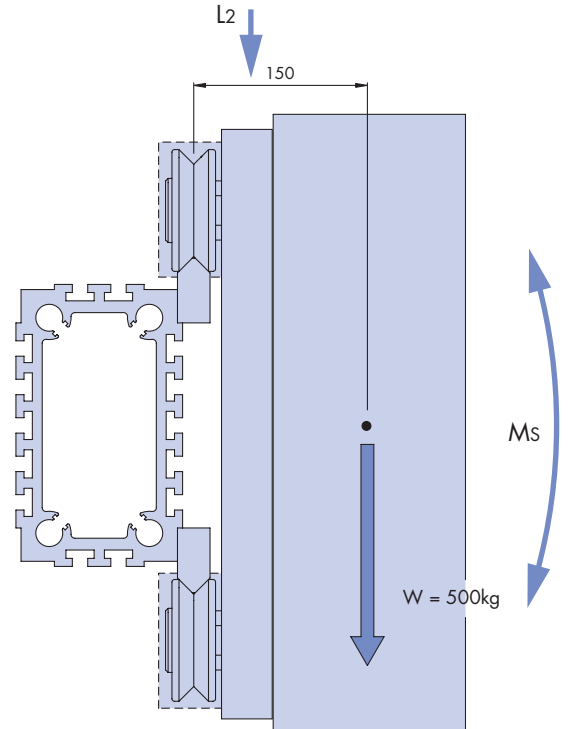

The values for $L_{1(\max)}$, $L_{2(\max)}$, $M_{s(\max)}$ can be taken directly from the table on page 1, the values for $M_{v(\max)}$, $M_{(\max)}$ can also be taken from that table, however the figure must be multiplied by 'D', which is the dimension between the bearings along the length of the carriage. This dimension can be found on page 26 of the full HDS2 catalogue.

'D' for a AU9525WCW is 290mm therefore, $M_{v(\max)} = 20 \times 290 = 5\,800\text{Nm}$, and $M_{(\max)} = 14 \times 290 = 4\,060\text{Nm}$.

$$L_f = \frac{0}{28000} + \frac{4905}{40000} + \frac{735.75}{3520} + \frac{0}{5800} + \frac{0}{4060} = 0.332$$

The basic life for this system (using THJR95 bearings in the lubricated condition) is taken from the table on page 2 - this is 400km. The system life is calculated as shown below.

$$\text{Life (km)} = \frac{\text{Basic Life}}{(0.04 + 0.96L_f)^3} = \frac{400}{(0.04 + 0.96 \times 0.332)^3} = 8\,690\text{km}$$

In this duty the system travels $0.4\text{m/s} \times 60 \times 60 \times 40$ (seconds / week) $\times 0.5$ (50% duty cycle) = 28 800 m = 28.8 km / week. 8 690km life equates to 301.7 weeks or **5.8 years**.

Example 2

A system consists of a carriage weighing 840kg with 2 BHJR95CNS and BHJR95ENS bearings. Lubrication is provided from 4 CW95 cap wipers. The carriage assembly runs on 2 PHSS25 V slides. The stroke length for the system is 1.6m. The only loading for the slide system is the weight of the carriage whose centre of mass is in the centre of the four bearing assemblies. The system runs at 0.6m/s on a 25% duty cycle for 45 hours per week.

Since the 8240N weight (= mass \times g = 840kg \times 9.81m/s² = 8240N) is central on the carriage, it is equally distributed between all four bearings. Each therefore experiences a load of 2060N.

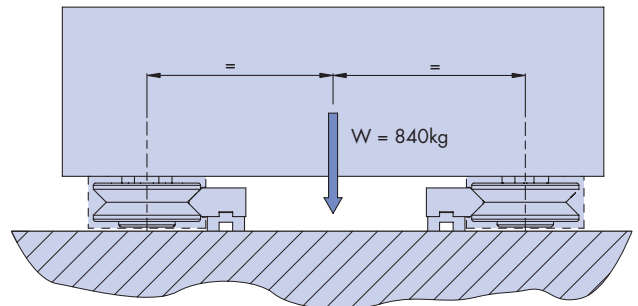

The load in this case is purely axial therefore $L_A = 2060$, $L_R = 0$. From this we can calculate the load factor according to the equation shown on page 2:

$$\text{Load Factor } L_f = \frac{L_A}{L_{A(\max)}} + \frac{L_R}{L_{R(\max)}} = \frac{2060}{7000} + \frac{0}{20000} = 0.294$$

No. 5 HDS2 Load Life Calculations + Examples

The basic life for this system (using THJR95 bearings in the lubricated condition) is taken from the table on page 2 - this is 400km. The system life is calculated as shown below.

$$\text{Life (km)} = \frac{\text{Basic Life}}{(0.04 + 0.96LF)^3} = \frac{400}{(0.04 + 0.96 \times 0.294)^3} = 11\,922 \text{ km}$$

In this duty, the system travels $0.6 \text{ m/s} \times 60 \times 60 \times 45$ (seconds / week) $\times 0.25$ (25% duty cycle) = 24 300m or 24.3km per week. The anticipated system life is therefore $11\,922 \text{ km} / 24.3 \text{ km} = 490$ weeks or about **9.4 years**.

Example 3

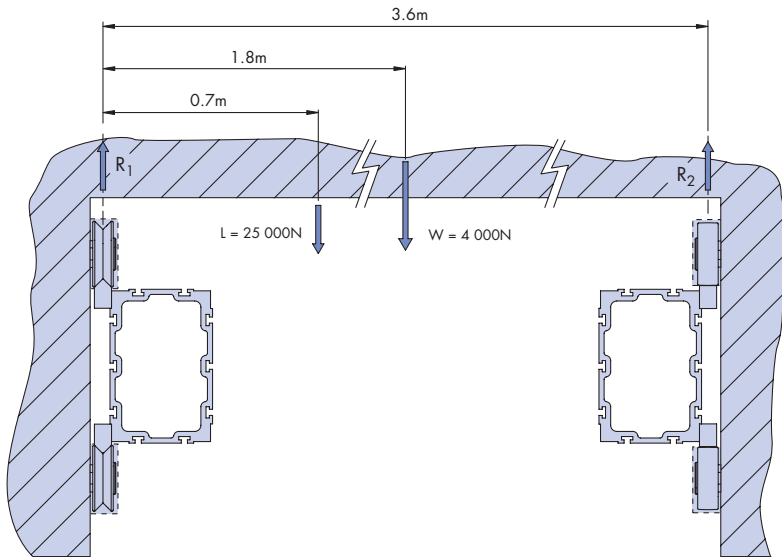

A large gantry machine uses 2 x CHSS33 V slides and 2 x CHTS33 flat tracks on which run a machine platform weighing 4 000N, whose centre of mass is in the middle of the system (see the drawing on the left). An external load of 25 000N is also carried, but this is only 0.7m from the centre line of the V slide. The load is carried by 2 x BHJR128CNS & 2 x BHJR128ENS V bearings combined with the V slide and 2 x BHRR122CNS & BHRR122ENS track rollers running on the flat track.

The system travels at 1m/s on a 10% duty cycle for 24 hours per day 6 days per week.

The load on each of the bearing elements is calculated using basic static methods.

[Summing all forces]

$$R_1 + R_2 = L + W = 25\,000 + 4\,000 \text{ N} = 29\,000 \text{ N}$$

[Taking moments about the V slide centre line]

$$L \times 0.7 \text{ m} + W \times 1.8 \text{ m} = 25\,000 \text{ N} \times 0.7 \text{ m} + 4\,000 \text{ N} \times 1.8 \text{ m} = R_2 \times 3.6 \text{ m}$$

[Therefore]

$$R_2 \times 3.6 = 24\,700 \text{ Nm} \therefore R_2 = 6861 \text{ N}$$

[Substituting into the first equation]

$$R_1 + 6861 \text{ N} = 29\,000 \text{ N} \therefore R_1 = 22\,139 \text{ N}$$

Both R1 and R2 are supported by two bearing elements, so the radial loads are: V bearings 11 069.5N; track rollers 3 430.5N

$$\text{Load Factor } LF \text{ for V bearings} = \frac{L_A}{L_{A(\max)}} + \frac{L_R}{L_{R(\max)}} = \frac{0}{10\,000} + \frac{11\,069.5}{30\,000} = 0.369$$

$$\text{Load Factor } LF \text{ for Track Rollers} = \frac{L_R}{L_{R(\max)}} = \frac{3\,430.5}{30\,000} = 0.114$$

Using the calculations on page 3, we can determine the system life based on the calculated load factors. The basic life for this system (using THJR128 bearings in the lubricated condition) is taken from the table on page 2 - this is 700km.

For V bearings:

$$\text{Life (km) for V Bearings} = \frac{\text{Basic Life}}{(0.04 + 0.96LF)^3} = \frac{700}{(0.04 + 0.96 \times 0.369)^3} = 11\,425 \text{ km}$$

The basic life for this system using THJR122 track rollers is taken from the table on page 3 - this is also 700km.

For track rollers:

$$\text{Life (km) for Track Rollers} = \frac{\text{Basic Life}}{LF^3} = \frac{700}{0.114^3} = 468\,155 \text{ km}$$

As can be seen from the above calculations the V bearings will be the life determining factor for the system.

In this duty the system travels $1 \text{ m/s} \times 60 \times 60 \times 24 \times 6$ (seconds / week) $\times 0.1$ (10% duty cycle) = 51840 m = 51.8 km / week. 11 425km life equates to 220.5 weeks or **4.2 years**.

No. 5 HDS2 Load Life Calculations + Examples

Example 4

A machine uses an AU15033WLB assembled carriage fitted to a HB33 beam with CHSS33 V slides to support a 10 000N load, which is offset by 750mm from the system centre as illustrated. The system moves at 0.4m/s for 40 hours per week on a 60% duty cycle. The loads on the carriage are determined as follows.

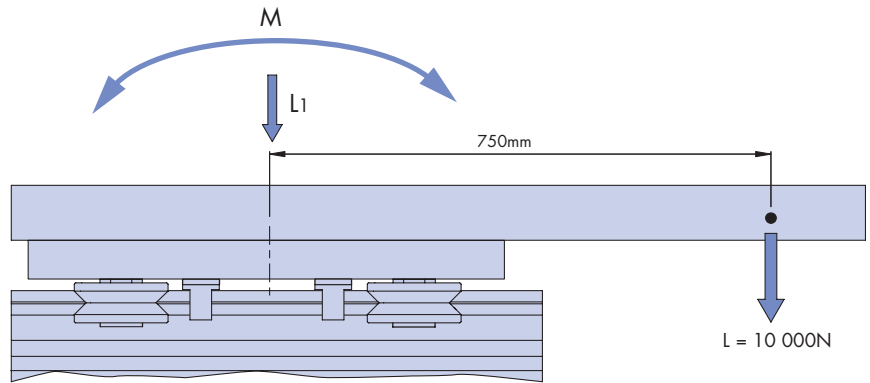

$$\text{Load Factor } LF = \frac{L_1}{L_{1(\max)}} + \frac{L_2}{L_{2(\max)}} + \frac{M_s}{M_{s(\max)}} + \frac{M_v}{M_{v(\max)}} + \frac{M}{M_{(\max)}}$$

$$L_2 = M_s = M_v = 0$$

$$L_1 = 10\,000\text{N}$$

$$M = 10\,000\text{N} \times 0.75\text{m} = 7500\text{Nm}$$

The values for $L_{1(\max)}$, $L_{2(\max)}$, $M_{s(\max)}$ can be taken directly from the table on page 1, the values for $M_{v(\max)}$, $M_{(\max)}$ can also be taken from that table, however the figure must be multiplied by 'D', which is the dimension between the bearings along the length of the carriage. This dimension can be found on page 26 of the full HDS2 catalogue.

'D' for an AU15033WLB is 435mm therefore, $M_{v(\max)} = 50 \times 435 = 21\,750\text{Nm}$, and $M_{(\max)} = 34 \times 435 = 14\,790\text{Nm}$.

$$LF = \frac{10\,000}{68\,000} + \frac{0}{100\,000} + \frac{0}{11\,110} + \frac{0}{21\,750} + \frac{7500}{14\,790} = 0.654$$

The basic life for this system (using THJR150 bearings in the lubricated condition) is taken from the table on page 2 - this is 2000km. The system life is calculated using the life calculation for .HJR150.. bearings as shown on page 3.

$$\text{Life (km)} = \frac{\text{Basic Life}}{(0.04 + 0.96LF)^{3.3}} = \frac{2000}{(0.04 + 0.96 \times 0.654)^{3.3}} = 7\,573\text{km}$$

In this duty the system travels $0.4\text{m/s} \times 60 \times 60 \times 40$ (seconds / week) $\times 0.6$ (60% duty cycle) = 34 560m = 34.56 km / week. 7 573km life equates to 219 weeks or **4.2 years**.

HepcoMotion®, Lower Moor Business Park,
Tiverton Way, Tiverton, Devon, England EX16 6TG

Tel: +44 (0) 1884 257000

Fax: +44 (0) 1884 243500

E-mail: sales@hepcotion.com



INVESTOR IN PEOPLE

