



This data sheet
interacts with

HDS2 Catalogue



28 to 31
& 36

HepcoMotion®

No. 8 HDS2 Rack Driven Carriages

Please read this document in conjunction with 28-31 & 36 of the HDS2 catalogue.

The HDS2 rack driven carriage and beam assembly has been delivered in a partly assembled state, and the following instructions detail how to assemble the product and adjust the components to ensure the correct running conditions.

The system has been pre-assembled by Hepco to ensure all components are correctly supplied, and has only been disassembled for ease of shipment, and to avoid damage in transit. Assembly of the supplied components is a simple process, and can be completed in a short period of time.

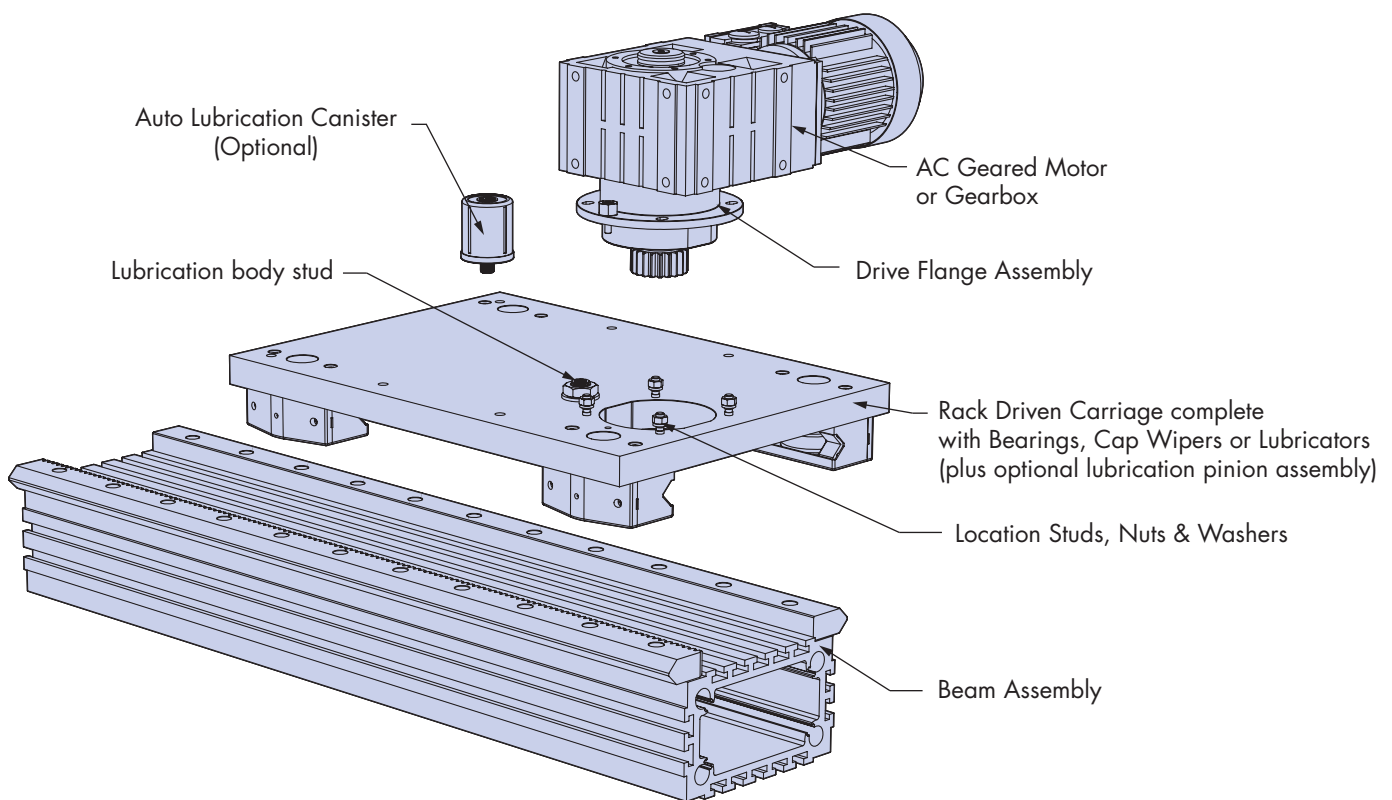

The AC geared motor or gearbox & the drive flange assembly will have been supplied assembled.

The rack driven carriage plate is supplied with bearings and, if specified on the order, cap wipers or lubricators. The bearings have been set to the beam assembly that was ordered with the carriage. In the case of multiple systems the individual carriages and beams will be identified as sets. The fixing nuts and washers for the drive flange assembly will be attached to the threaded studs on the carriage plate. These will need to be removed and put to one side, to allow assembly to take place (**do not discard**).

If ordered, the automatic lubrication canister will have also been removed. Details on setting this can be found on 4.

No. 8 HDS2 Rack Driven Carriages

The carriage should be engaged with the slides from one end of the beam assembly, making sure that the cap wiper / lubricator felts are pushed back into the body, which will allow easy engagement of the carriage with the slides.

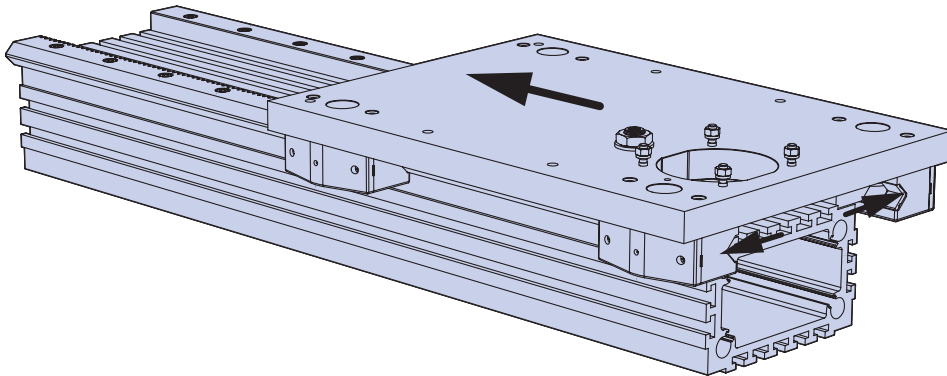

With the nuts and washers removed from the location studs, orientate the geared motor so that its position matches the application requirements. For information on geared motor orientation please refer to the full HDS2 catalogue [□29](#).

Lower the geared motor assembly into the recess in the carriage, as shown below.

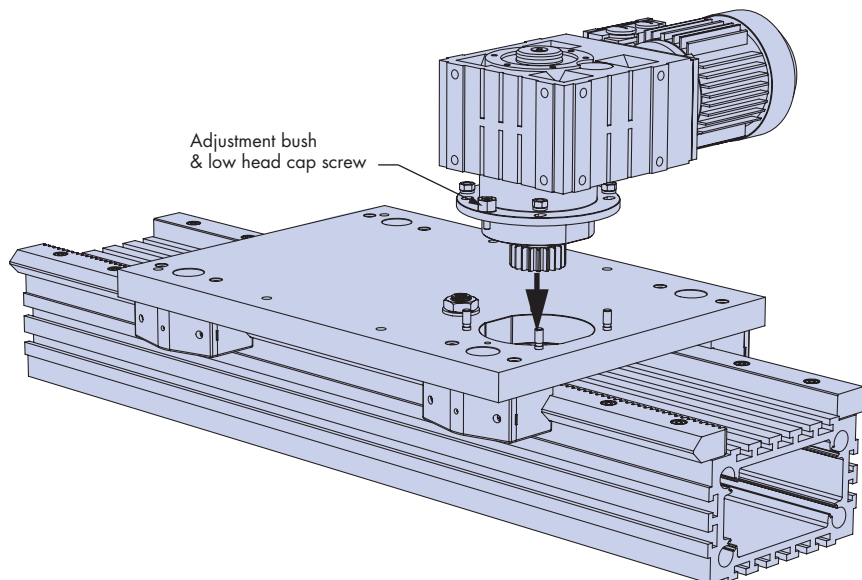

Assemble the nuts and washers on to the location studs, and tighten to finger tight. Fit the adjustment bush into the slotted hole in the drive flange assembly, and lightly secure the low head cap screw into the tapped hole in the carriage through the centre of the adjustment bush.

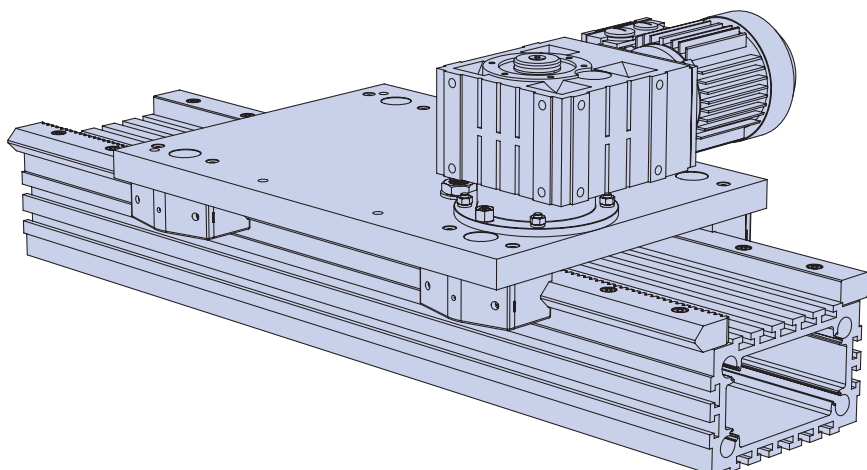

No. 8 HDS2 Rack Driven Carriages

Using a suitably sized spanner and hex key, hold the low head cap screw in position and rotate the adjustment bush as shown below. The rotation of the bush will cause the geared motor assembly to move in and out of engagement with the rack.

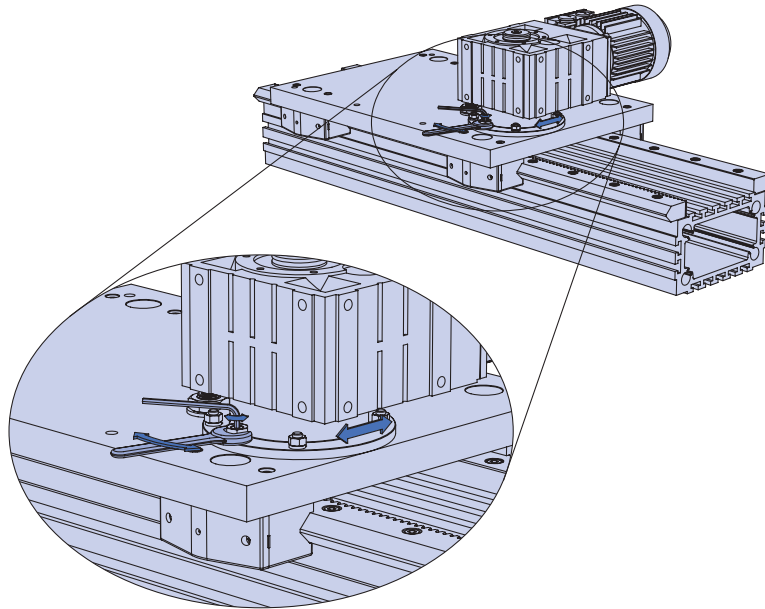

The movement of the geared motor assembly controls the amount of backlash between the pinion and rack. To measure this movement, attach a suitable measuring device to the fixed slides and measure the free movement in the carriage. A dial test indicator with magnetic base is ideal for this, (see below). With the assembly adjusted so that the assembly is at its furthest position from the rack, measure the free play in the carriage. This can be done by pushing / pulling the carriage until the pinion starts to rotate.

Slowly adjust the assembly until the required amount of backlash is achieved. Hepco recommends a figure of 0.1 to 0.2mm, however this will depend on the application.

Once the required backlash is achieved, tighten all fixing nuts on the drive flange assembly, and finally tighten the low head cap screw holding the adjustment bush. Check the amount of backlash again to ensure that the position has not changed.

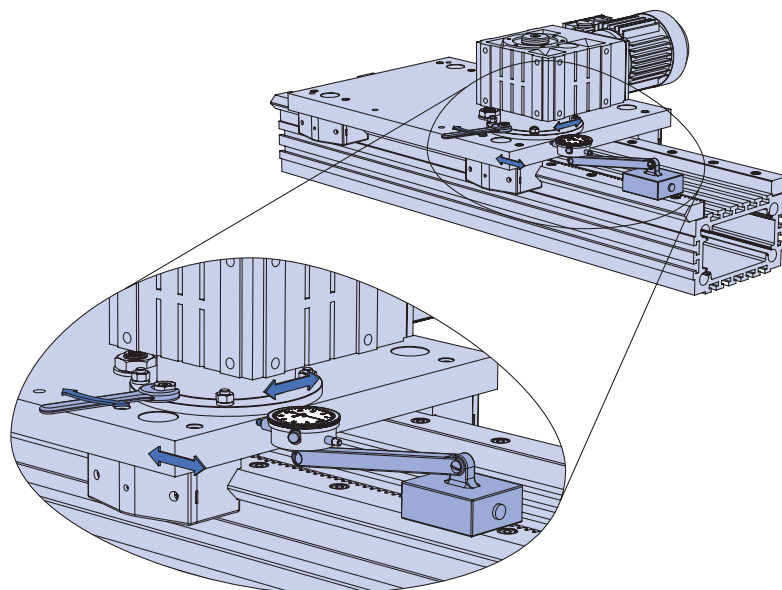

No. 8 HDS2 Rack Driven Carriages

Automatic Rack Lubrication Adjustment

Important - The optional lubrication pinion is for top up lubrication only. A film of grease should be applied to the rack prior to starting the system to ensure correct lubrication on the mating surfaces.

The optional lubrication pinion assembly should be adjusted as follows:

Using a suitable size spanner and hex key, hold the body on the stud in place with the hex key inserted into the stud, and loosen the nut. The body of the stud, where the pinion is attached, is eccentric, therefore as the body is rotated the pinion will move in and out of mesh with the rack. Adjust the pinion so that it is just in mesh with the rack but does not apply any resistance to movement of the carriage. Once in the correct position, tighten the nut with the spanner.

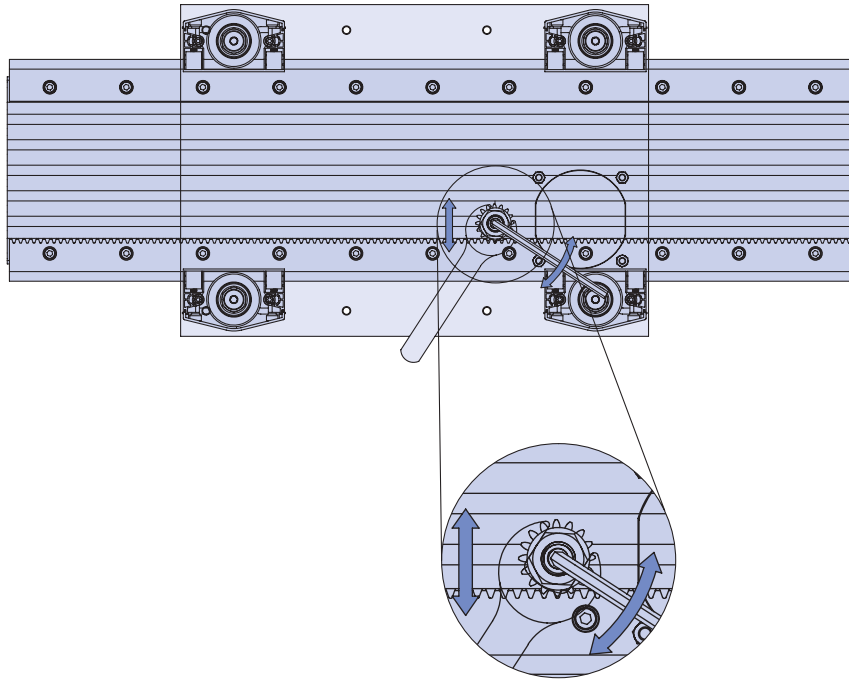

It is important that the body of the stud and pinion are purged with grease prior to fitting the canister to ensure correct grease flow. Pump grease into the stud body until it is seen to emerge from the holes in the face of the pinion. This may be done directly without fitting a grease nipple.

Remove the spanner and hex key and screw the lubrication canister into the thread in the top of the body.

The canister can be set to discharge its contents of grease over a given period of time, the settings are in months from 1~12 months, Hepco recommends an initial setting of 4-6 months, however this will depend on the application and it is important to regularly inspect the system to ensure that enough grease is being discharged onto the rack, and the setting adjusted to compensate.

Depending on the type of canister a small hex key, or wide flat blade screwdriver will be required to adjust the setting.

It is important to set the discharge period on the canister, as the unit is switched off on delivery and no grease will be discharged unless this setting is changed.

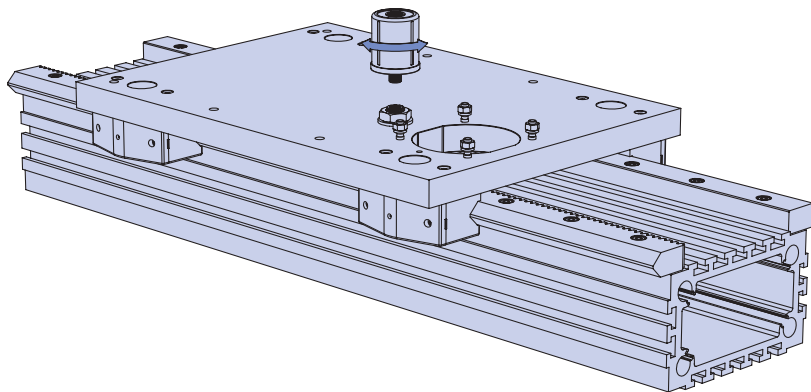

HepcoMotion[®], Lower Moor Business Park,
Tiverton Way, Tiverton, Devon, England EX16 6TG

Tel: +44 (0) 1884 257000

Fax: +44 (0) 1884 243500

E-mail: sales@hepcotion.com



INVESTOR IN PEOPLE



HEPCO[®]
www.HepcoMotion.com