

## SBD Long Carriage Option

SBD units in both standard and cleanroom versions are available with a long carriage option. This version has two LBG bearing blocks in the carriage and has much improved load capacity, particularly in M & Mv directions. The main dimensions of the standard long carriage SBD units are shown below. Further details can be obtained from the 3D CAD files available from Hepco's technical department or at [www.HepcoMotion.com](http://www.HepcoMotion.com). Standard & cleanroom units are supplied in increments of 60mm (SBD20-80) and 80mm (SBD30-100) up to 6000mm. Longer units are made from more than one piece. The nominal stroke length is calculated with the carriage against the internal buffers. In practice a clearance should be provided to allow for overrun. Re-lubrication of the ball guide carriage blocks is via two access points in the side of the beam (see below), and closed off with a threaded plug. The lubrication interval depends on length of stroke, speed and duty, contact Hepco's technical department for further details.

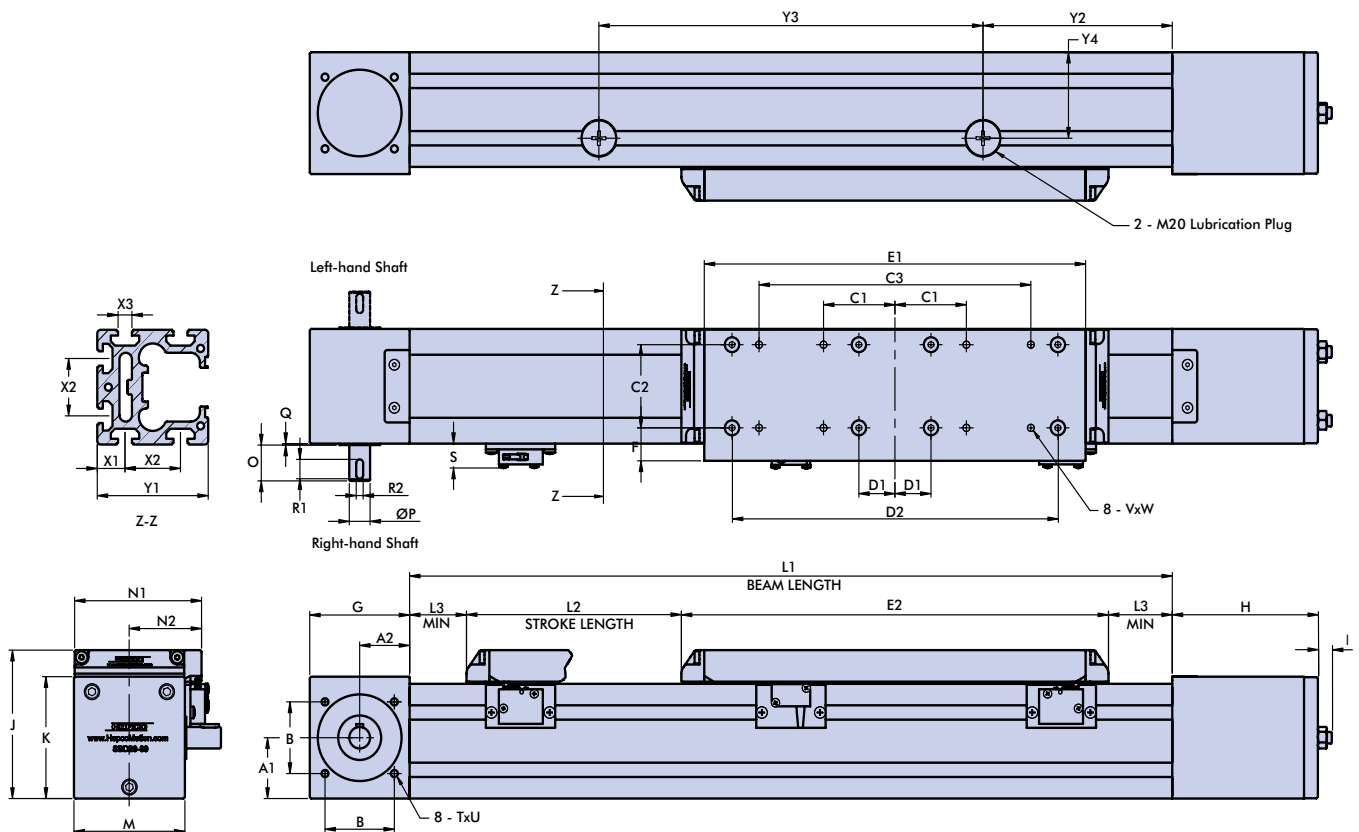

SBD Unit	A1	A2	B	C1	C2	C3	D1	D2	E1	E2	F	G	H	I	J	K	L1 (min)	L2 Nominal Stroke	L3 (min)
SBD20-80	42.4	36	50	51.5	58	196	26	235	275	308	23	72	105	12	103.5	85	550	L1 - 390	41
SBD30-100	51.6	48	65	65	76	260	46	295	340	373	24.5	96	145.5	13	123.5	105	580	L1 - 470	48.5

SBD Unit	M	N1	N2	O	P	Q	R1	R2	S	TxU	VxW	X1	X2	X3	Y1	Y2	Y3	Y4
SBD20-80	80	91.5	52	25	15	1	13.5	5	17	M6 x 15	M6 x 9.5	20	40	10	80	162.5	205	60
SBD30-100	100	112	62.5	36	20	1	22	6	17	M6 x 15	M8 x 9.5	30	40	10	100	164	252.5	70

# SBD Long Carriage Option

The cleanroom version of the SBD unit has been designed to meet an increasing demand for clean manufacturing processes and environments. This version of the SBD unit is ready for connection to vacuum extraction which minimises particle emissions. All external parts are made from anodised aluminium or stainless steel. This SBD cleanroom unit is certified by the Fraunhofer IPA Institute for use in cleanroom environments and meets air cleanliness class 3 according to ISO 14644-1. For further details please visit [www.HepcoMotion.com/sbdatauk](http://www.HepcoMotion.com/sbdatauk) and select datasheet No. 5 cleanroom qualification. The main dimensions of the cleanroom long carriage SBD units are shown below. Further details can be obtained from the 3D CAD files available from Hepco's technical department or at [www.HepcoMotion.com](http://www.HepcoMotion.com).

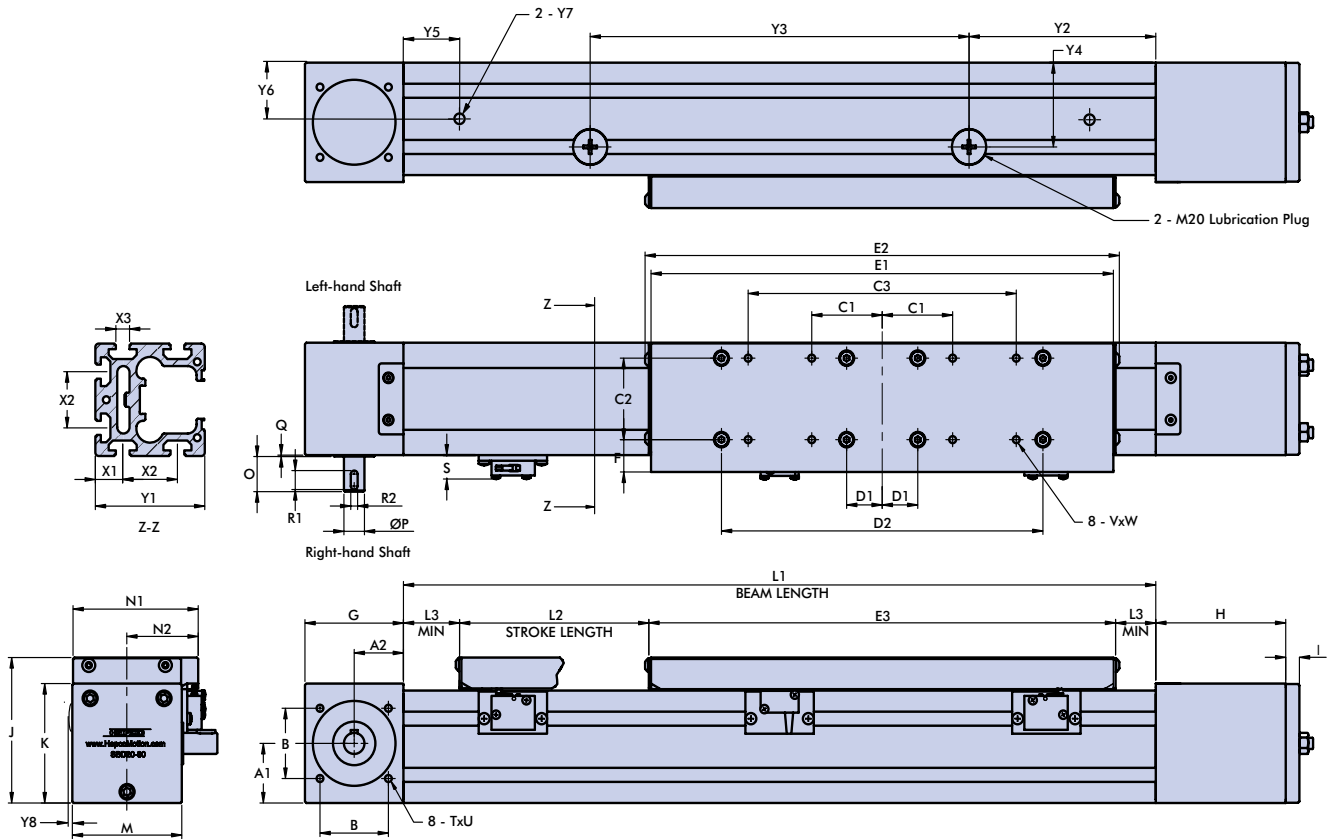

SBD Unit	A1	A2	B	C1	C2	C3	D1	D2	E1	E2	E3	F	G	H	I	J	K	L1 (min)	L2 Nominal Stroke	L3 (min)
SBD20-80	42.4	36	50	51.5	58	196	26	235	338	347	341	23	72	105	12	103.5	85	550	L1 - 390	24.5
SBD30-100	51.6	48	65	65	76	260	46	295	404	413	407	24.5	96	145.5	13	123.5	105	580	L1 - 470	31.5

SBD Unit	M	N1	N2	O	P	Q	R1	R2	S	TxU	VxW	X1	X2	X3	Y1	Y2	Y3	Y4	Y5	Y6	Y7	Y8
SBD20-80	80	91.5	52	25	15	1	13.5	5	17	M6 x 15	M6 x 9.5	20	40	10	80	162.5	205	60	40	40	1/4" BSPP	2
SBD30-100	100	112	62.5	36	20	1	22	6	17	M6 x 15	M8 x 9.5	30	40	10	100	164	252.5	70	40	50	3/8" BSPP	2

The vacuum extraction connection holes (see dimensions Y5 & Y6) can be repositioned to suit customer requirements or deleted. Hepco can supply vacuum connections pre-fitted on request.

# Technical Data

The nominal load capacities for the SBD long carriage units are based on LBG ball guide dynamic load capacities combined with a mounting factor of 0.8 (see LBG catalogue 19). They are shown in the table below for each of the 5 direct and moment loading directions. For guidance on load life calculations please refer to the SBD catalogue 8 and visit [www.HepcoMotion.com/sbddatauk](http://www.HepcoMotion.com/sbddatauk) and select datasheet No.2 load life calculations.

SBD Unit	L1	L2	Ms	Mv	M
SBD20-80	33920N	33920N	302Nm	1150Nm	1150Nm
SBD30-100	68800N	68800N	848Nm	2990Nm	2990Nm

The table below includes the parameters necessary to calculate the performance and duty of an SBD system.

Parameter			SBD20-80		SBD30-100	
			Standard	Cleanroom	Standard	Cleanroom
Mass of carriage	Mc	kg	2.3	2.5	5.2	5.5
Mass of belt per m	Mb	kg/m	0.12		0.34	
Mass of SBD unit	Mu	kg	9.7 x L + 6.9	9.7 x L + 7.2	15.7 x L + 13.7	15.7 x L + 14.0
Pulley radius	r	cm	2.39		3.5	
Drive efficiency			0.9		0.9	
Break away friction	Fba	N	29	14	46	36
Coefficient of friction	μ		0.01		0.01	
Beam moment of inertia*	I <sub>xx</sub>	mm <sup>4</sup>	1500000		3700000	
	I <sub>yy</sub>		1800000		4600000	
Max linear force (belt)	Fmax	N	1000		3300	
Linear movement per shaft rev		mm	150		220	
Belt tooth pitch		mm	5		10	
LBG carriage basic load rating (dynamic)	C	N	33920		68800	

\* The beam moment of inertia figure is used in the calculation of beam deflection, with a high figure corresponding to a stiff beam. For further guidance on beam deflection calculations please visit [www.HepcoMotion.com/sbddatauk](http://www.HepcoMotion.com/sbddatauk) and select datasheet No. 3 SBD beam deflection calculations.

## Ordering Details

	SBD	20-80	L1750	C2	RS	B2
SBD = product range	_____	_____	_____	_____	_____	_____
Size of unit: Choose <b>20-80</b> or <b>30-100</b>	_____	_____	_____	_____	_____	_____
Beam Length. Beams lengths available in increments of 60mm from 550mm for SBD20-80 and increments of 80mm from 580mm for SBD30-100, see	_____	_____	_____	_____	_____	_____
Unit type: <b>C1</b> = corrosion resistant; <b>C2</b> = cleanroom; leave <b>blank</b> for standard unit	_____	_____	_____	_____	_____	_____
Drive shaft: <b>LS</b> for left-hand; <b>RS</b> for right-hand; <b>DS</b> for double shaft	_____	_____	_____	_____	_____	_____
Long carriage option with twin LBG bearing blocks: <b>B2</b>	_____	_____	_____	_____	_____	_____

# Notes

**HepcoMotion®**, Lower Moor Business Park,  
Tiverton Way, Tiverton, Devon, England EX16 6TG

**Tel: +44 (0) 1884 257000**

**Fax: +44 (0) 1884 243500**

**E-mail: [sales@hepcotion.com](mailto:sales@hepcotion.com)**



INVESTOR IN PEOPLE



**HEPCO®**  
[www.HepcoMotion.com](http://www.HepcoMotion.com)