

This datasheet interacts with the catalogues below

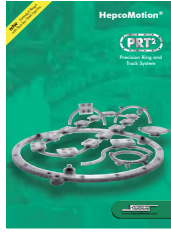

# HepcoMotion®

## Vacuum & Extreme Temperature Bearings and Track Rollers

HepcoMotion® Vacuum & Extreme Temperature Bearings and Track Rollers are designed for extreme environments. They are available in sizes from 18 to 54mm in diameter, with a broad range of fixing styles, and with load capacities from 180 to 4,200N. They can be used with stainless steel linear and curved slides from the Hepco SL2 and PRT2 ranges.

Both the VACSS range of vacuum & high temperature bearings and the LTSS range of low temperature bearings use components which are entirely made from stainless steel. Their construction and materials are shown below.

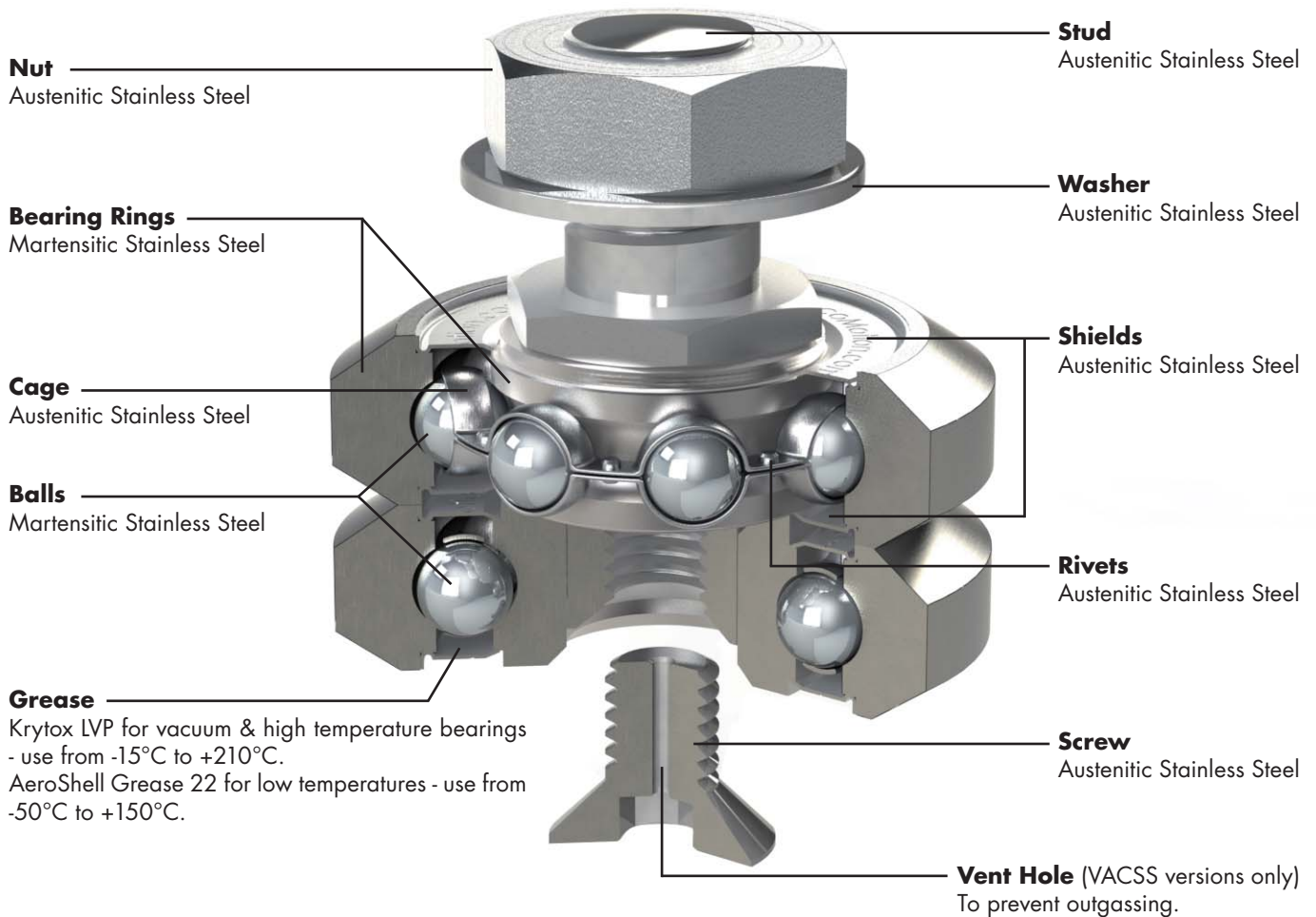

...BHJ34E, See 3



Track Roller, See 4

# Vacuum & High Temperature Bearings



Hepco VACSS Vacuum & High Temperature Bearings are made entirely from stainless steel parts and are lubricated internally for life using Krytox LVP grease. They are suitable for use in high vacuum, at temperatures from -15°C to +210°C, and in the presence of oxygen. They are widely used in applications including semiconductor wafer manufacture, aerospace components, vapour deposition processes, LCD panel and plasma display manufacture and in vacuum evaporation equipment.

The bearings have the same dimensions as those in the HepcoMotion SL2 range (visit [www.HepcoMotion.com/SL2datauk](http://www.HepcoMotion.com/SL2datauk) and select SL2 catalogue 12-13). They are compatible with SL2 stainless steel linear slides, as well as the stainless steel rings and tracks in the Hepco PRT2 range (visit [www.HepcoMotion.com/PRT2datauk](http://www.HepcoMotion.com/PRT2datauk)).

The ...J18... bearings have a different construction to the larger sizes, using a one-piece outer wheel into which two smaller bearings are fitted. This size is not available in the low temperature LTSS version.

These bearings can be supplied with alternative grease, without grease or without shields, on request.

## Through Fixing Type (SJ/LJ)

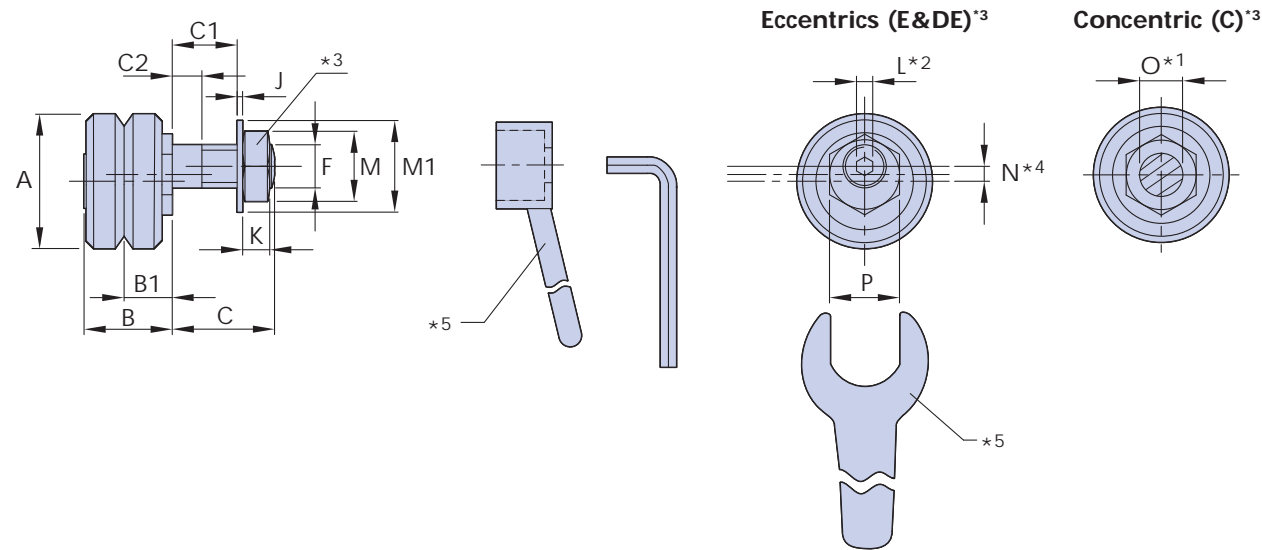

| Part Number | A  | B    | B1   | C    |    | C1  |      | C2  |     | D<br>±0.025 | E  | F<br>Metric Fine | G  | H   | I    | J    | K   | L   | M  | M1 | N <sup>4</sup> |       | O <sup>1</sup><br>+0.0<br>-0.03 | P  |
|-------------|----|------|------|------|----|-----|------|-----|-----|-------------|----|------------------|----|-----|------|------|-----|-----|----|----|----------------|-------|---------------------------------|----|
|             |    |      |      | SJ   | LJ | SJ  | LJ   | SJ  | LJ  |             |    |                  |    |     |      |      |     |     |    |    | ...E           | ...DE |                                 |    |
| ...J18...   | 18 | 12.4 | 6.75 | 7.4  | 14 | 3.4 | 10   | 2.4 | 2.5 | 14.00       | 7  | M6 x 0.75        | 10 | 0.6 | 7.4  | 0.8  | 3.2 | 2.5 | 10 | 13 | 0.7            | 2.6   | 6                               | 11 |
| ...J25...   | 25 | 16.6 | 9    | 9.8  | 19 | 3.8 | 13   | 2.2 | 4.9 | 20.27       | 10 | M8 x 1           | 14 | 0.5 | 9.8  | 1    | 5   | 3   | 13 | 17 | 0.75           | 2.75  | 8                               | 13 |
| ...J34...   | 34 | 21.3 | 11.5 | 13.8 | 22 | 6.6 | 14.8 | 5.2 | 5.9 | 27.13       | 12 | M10 x 1.25       | 18 | 0.7 | 13.8 | 1.25 | 6   | 4   | 17 | 21 | 1              | 3.6   | 10                              | 15 |
| ...J54...   | 54 | 34.7 | 19   | 17.8 | 30 | 8.2 | 20.4 | 5.7 | 7.9 | 41.76       | 25 | M14 x 1.5        | 28 | 1.6 | 17.8 | 1.6  | 8   | 6   | 22 | 28 | 1.5            | 5.5   | 14                              | 27 |

| Q | R <sup>4</sup> | S    | S1   | T    | T1   | T2   | U<br>±0.1 | U1   | V  | W    | X  | Y   | Z  | Adjusting Wrench <sup>5</sup> | Socket Tool <sup>5</sup> | Max Working Load Capacities (N) <sup>6</sup> |        |       |        | Basic Life <sup>6</sup> |     | Weight g |         |        |        | Part Number |
|---|----------------|------|------|------|------|------|-----------|------|----|------|----|-----|----|-------------------------------|--------------------------|--|--------|-------|--------|-------------------------|-----|----------|---------|--------|--------|-------------|
|   |                |      |      |      |      |      |           |      |    |      |    |     |    |                               |                          | Lubricated                                   |        | Dry   |        | Lubricated              | Dry | SJ..C/E  | LJ..C/E | BHJ..C | BHJ..E |             |
|   |                |      |      |      |      |      |           |      |    |      |    |     |    |                               |                          | Axial  | Radial | Axial | Radial |                         |     |          |         |        |        |             |
| 2 | 1.2            | 8    | 10.5 | 10   | 4    | 8    | 38        | 54   | 11 | 24.5 | M4 | 7   | 7  | AT18                          | RT6                      | 60   | 180    | 36    | 72     | 80                      | 50  | 19       | 20      | 18     | 45     | ...J18...   |
| 3 | 1.5            | 7    | 9    | 12   | 5    | 10   | 50        | 72   | 14 | 32   | M5 | 8.5 | 10 | AT25                          | RT8                      | 240  | 450    | 80    | 160    | 50                      | 70  | 48       | 51      | 43     | 105    | ...J25...   |
| 4 | 2.0            | 9.5  | 8.5  | 17.5 | 6.5  | 12.5 | 60        | 90.5 | 17 | 42   | M6 | 10  | 14 | AT34                          | RT10                     | 520  | 900    | 160   | 320    | 100                     | 100 | 115      | 120     | 105    | 235    | ...J34...   |
| 8 | 3.0            | 14.5 | 16.4 | 23.5 | 10.5 | 18.5 | 89.5      | 133  | 25 | 62   | M8 | 13  | 20 | AT54                          | RT14                     | 1,350  | 2,400  | 360   | 720    | 250                     | 150 | 415      | 425     | 390    | 800    | ...J54...   |

### Notes:

- It is recommended that holes to suit bearing mounting studs should be reamed to tolerance F6 for a sliding fit.
- Eccentric bearing fixing studs are supplied with hexagon sockets for adjustment as shown.
- Nuts and washers are supplied with both concentric and eccentric SJ/LJ type bearings.
- 'N' is the eccentric offset due to the eccentric design (2 x N = total stroke). R dimension is both the eccentric offset of the adjusting nut and total stroke at the bearing centreline.
- For adjusting tool part numbers see table. For adjustment procedure and fixing nut tightening torques see HepcoMotion SL2 catalogue 20.
- To calculate the load capacity and life of systems using these bearings, please use the methods shown in the HepcoMotion GV3 catalogue (visit [www.HepcoMotion.com/GV3datauk](http://www.HepcoMotion.com/GV3datauk) and select GV3 catalogue 59).

# Low Temperature Bearings



Hepco LTSS Low Temperature Bearings are lubricated internally for life using AeroShell Grease 22 which is suitable for use at temperatures from -50°C to +150°C. This lubricant enables use in much colder conditions than the VACSS bearings, opening up applications in cold stores and specialised freeze dry equipment.

**Through Hole Fixing** type is available in two stud lengths covering most thicknesses of mounting plate. Both are available in **Concentric (C)** which are fixed, **Eccentric (E)**, adjustable, and **Double Eccentric (DE)** which have sufficient adjustment to enable a carriage to be disengaged from the slide.

**Blind Hole Fixing type (BHJ)** allows mounting into a solid machine base where through mounting holes are not possible, or where the thickness of the mounting plate is too great. The Blind Hole Fixing type is also useful where adjustment from the front is preferred or where access to the opposite side of the mounting hole is restricted. They are available in **Concentric (C)** which are fixed, or **Eccentric (E)** which are adjustable.

## Blind Hole Fixing Type (BHJ)

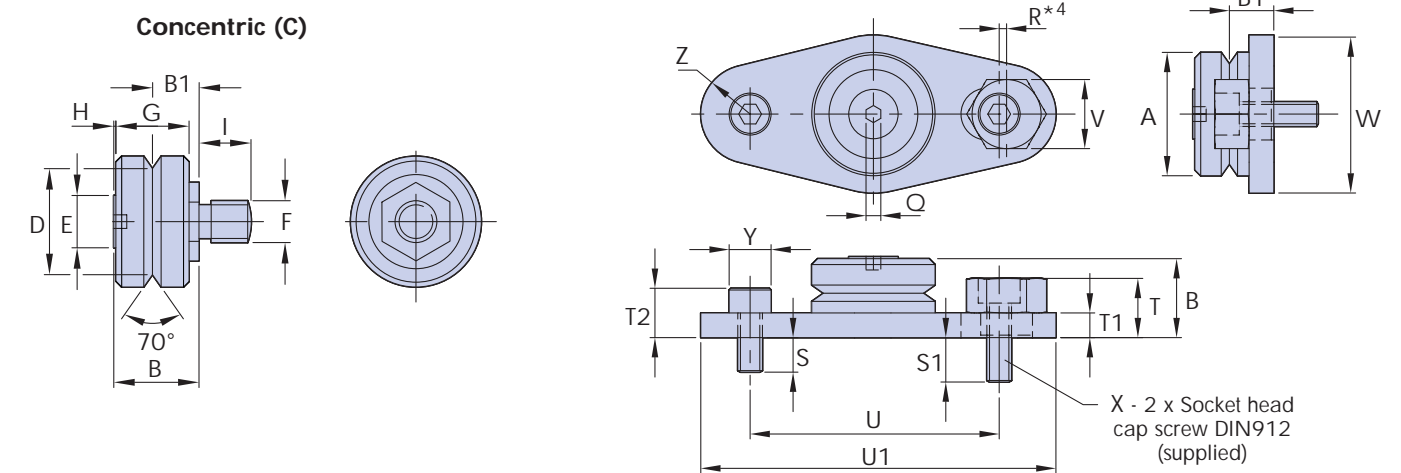

## Ordering Details

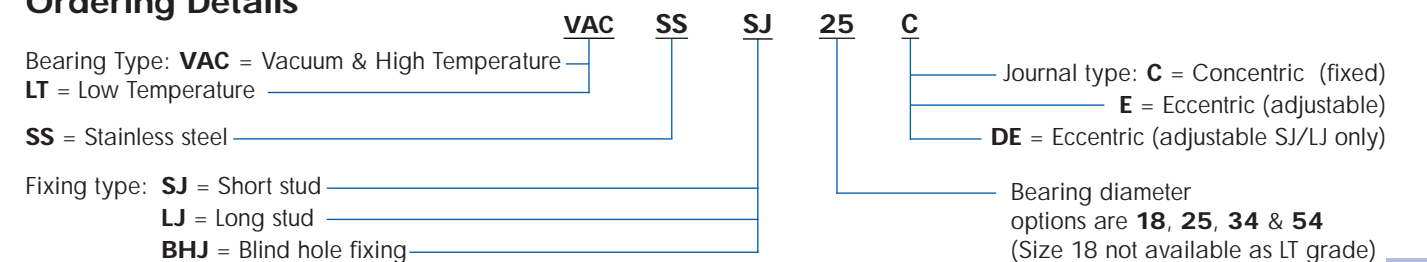

# Vacuum & Extreme Temperature Track Rollers



HepcoMotion Vacuum & High Temperature and Low Temperature Track Rollers are available mounted on both concentric and eccentric through hole fixing studs. They are available in diameters 25, 34 & 54mm with load capacities up to 4,200N. Track rollers can be run with any suitable flat track, or can be used as cam-followers.

Materials and greases are the same as are used on the VACSS vacuum & high temperature and LTSS low temperature V bearings shown on the previous pages.

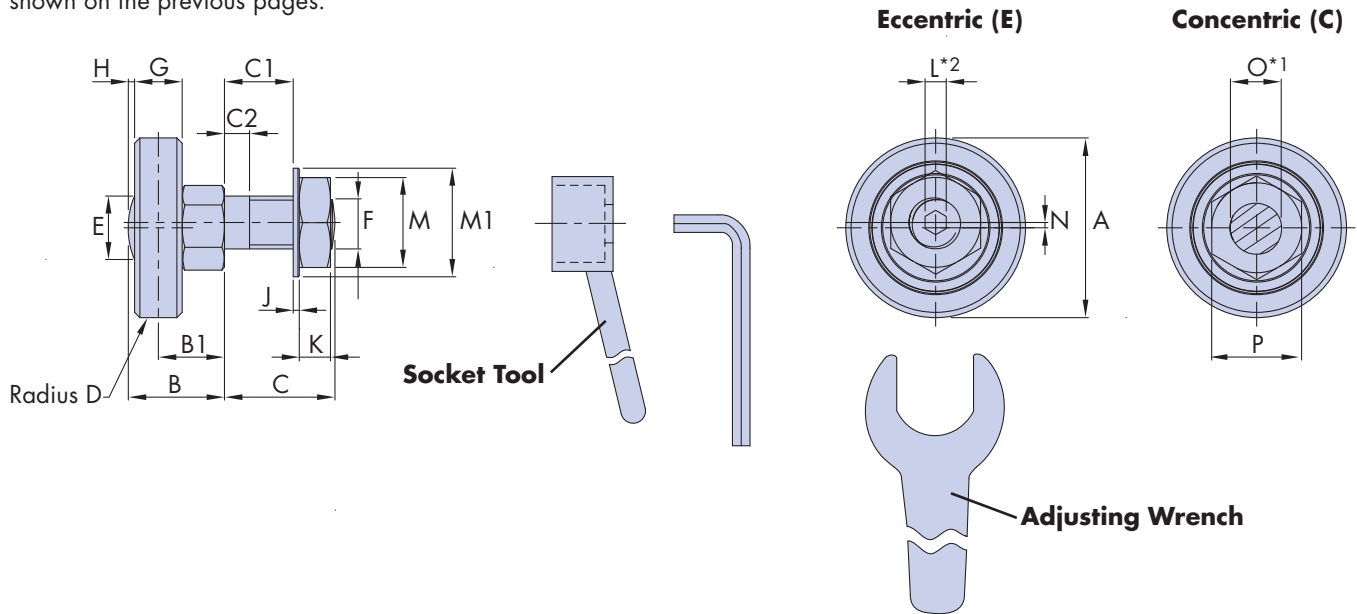

| Part Number | A  | B    | B1   | C  | C1   | C2 | D   | E    | F<br>Metric Fine | G  | H   | J    | K |
|-------------|----|------|------|----|------|----|-----|------|------------------|----|-----|------|---|
| ...LRN25... | 25 | 14.5 | 10   | 19 | 13   | 5  | 500 | 10   | M8x1             | 7  | 1   | 1    | 5 |
| ...LRN34... | 34 | 18.2 | 12.5 | 22 | 14.8 | 6  | 500 | 12   | M10x1.25         | 9  | 1.2 | 1.25 | 6 |
| ...LRN54... | 54 | 29.5 | 21   | 30 | 20.4 | 8  | 500 | 23.5 | M14x1.5          | 14 | 1.4 | 1.6  | 8 |

| L <sup>2</sup> | M  | M1 | N    | O <sup>1</sup><br>+0<br>-0.03 | P  | Adjusting<br>Wrench<br> | Socket<br>Tool<br> | Weight<br>g<br> | Max Working<br>Load Capacity <sup>4</sup> | Roller Static and Dynamic<br>Radial Load Capacities (N) <sup>3</sup> |        |
|----------------|----|----|------|-------------------------------|----|-------------------------|--------------------|-----------------|---|--|--------|
|                |    |    |      |                               |    |                         |                    |                 |   | Co   | C      |
| 3              | 13 | 17 | 0.75 | 8                             | 13 | AT25                    | RT8                | 40              | 800                                       | 1,092  | 2,632  |
| 4              | 17 | 21 | 1    | 10                            | 15 | AT34                    | RT10               | 85              | 1,400                                     | 1,905  | 4,078  |
| 6              | 22 | 28 | 1.5  | 14                            | 27 | AT54                    | RT14               | 310             | 4,200                                     | 5,319  | 10,965 |

## Ordering Details

Bearing Type: **VAC** = Vacuum & High Temperature  
**LT** = Low Temperature  
**SS** = Stainless steel  
**LRN** = Indicates a track roller, 25 denotes the diameter in mm  
**C** = Concentric (fixed) or **E** = Eccentric (Adjustable)

### Notes:

- It is recommended that holes to suit Track Roller mounting studs should be reamed to tolerance F6 for a sliding fit.
- Eccentric Track Roller fixing studs are supplied with hexagon sockets for adjustment as shown.
- The quoted static and dynamic load capacities are based on industry standard calculations. These do not accurately reflect system performance, and are only provided for comparison with other systems.
- Please use the Max Working Load figures and the load/life calculations shown in the HepcoMotion GV3 catalogue to determine roller performance (visit [www.HepcoMotion.com/GV3datauk](http://www.HepcoMotion.com/GV3datauk) and select GV3 catalogue 60).

HepcoMotion®, Lower Moor Business Park,  
 Tiverton Way, Tiverton, Devon, England EX16 6TG

Tel: +44 (0) 1884 257000

Fax: +44 (0) 1884 243500

E-mail: [sales@hepcotion.com](mailto:sales@hepcotion.com)

