

Linear actuator Econom 01

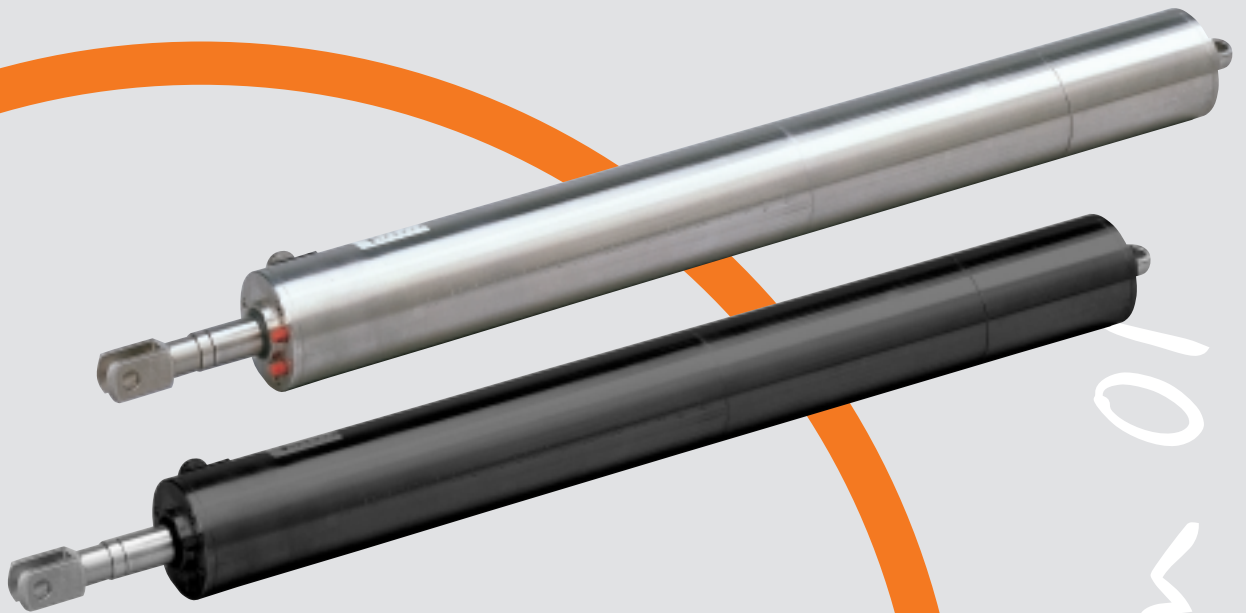

*Our intelligent model:  
Econom 01*



*Econom 01*

# Linear actuators Econom 01

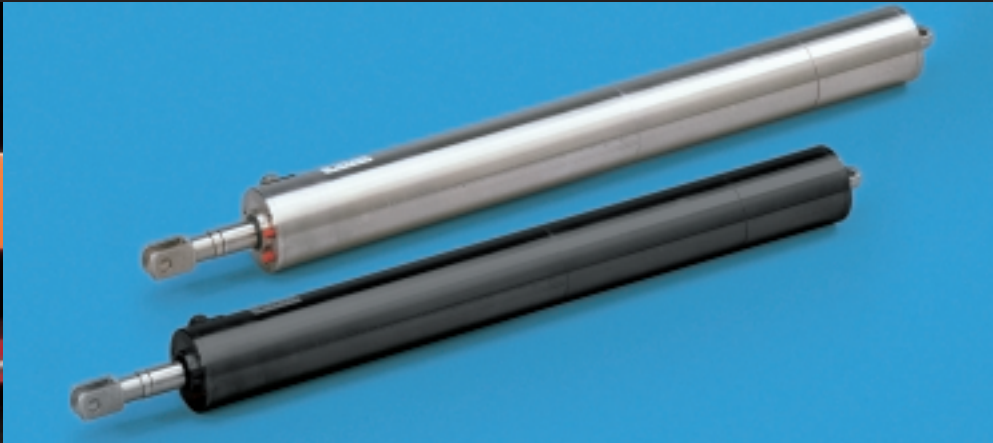

## Description · Applications · Facts

The users of the Econom 01 come from many different industries: From architects and planners of contemporary façade architecture up to plant construction and mechanical engineering specialists.

Using either the steel or the stainless steel versions of the Econom 01, a wide variety of applications is possible.

### Calculation example Econom 01 for dimension A

(based on the following requirements)

Pushing and pulling force	1400 N
Stroke	230 mm
Operating voltage	230 V 1 AC, rating: S3-15%
Fixing on piston end	fixed articulated lug
Fixing on housing end	standard articulated lug
Capacitor	external (standard wiring diagram WS 0500)
Option	potentiometer

### Selected version:

Force	→ version D	2000 N
Dimension G	→ fixed articulated lug	35 mm
Dimension F	→ ver. D, stroke 50-450 mm	363 mm (Please observe the additional marks *, **, 1)
Inst. stroke**	→ installed stroke length	250 mm
Dimension L	→ option, potentiometer	75 mm
Dimension E	→ standard articulated lug	17 mm
<b>Dimension A min.</b>		<b>740 mm</b>

\* brake dimension (75 mm) included \*\* installed stroke length at 50 mm intervals  
1) including 50 mm guide extension

## Load (N) and stroke speeds (mm/s)

Version	Stroke speed mm/s	400 V-3 AC Rating: S3 – 15%		400 V-3 AC Rating: S1		230 V-1 AC Rating: S3 – 15%		24 V DC Rating: S3 – 15%			24 V DC Rating: S1			Number of add. planetary gear stages	Available with brake only
		Load N	Nominal current A	Load N	Nominal current A	Load N	Nominal current A	V mm/s	Load N	Nom. current A	V mm/s	Load N	Nom. current A		
A	90	1000	1.0	–	–	500	2.5	75	600	10	–	–	–	–	x
B	55	1900	1.0	–	–	900	2.5	(50)	(1000)	10	–	–	–	–	x
C	45	2000	1.2	–	–	1000	2.5	40	800	10	–	–	–	–	x
D	28	3800	1.2	–	–	2000	2.5	(25)	(1500)	10	–	–	–	–	x
E	12	5000	1.0	900	0.25	4600	2.5	10	4000	10	12	1800	5.0	1	x
F	7	5000	1.0	2000	0.25	5000	2.5	6.5	5000	10	7.5	3000	5.0	1	x
G	4	5000	1.0	3500	0.25	5000	2.5	(4.5)	(5000)	6.0	(5)	(4000)	5.0	1	–
H	3	5000	1.0	4600	0.25	5000	2.5	–	–	5.0	3	5000	5.0	2	–
I	1.8	–	1.0	5000	0.25	5000	2.5	–	–	3.5	2	5000	3.5	2	–
J	1.1	–	1.0	5000	0.25	5000	2.5	–	–	3.0	1.2	5000	3.0	2	–
K	0.7	–	1.0	5000	0.25	5000	2.5	–	–	2.5	(0.8)	(5000)	2.5	2	–

( ) Added surcharge for special model!

# Technical data and dimensions

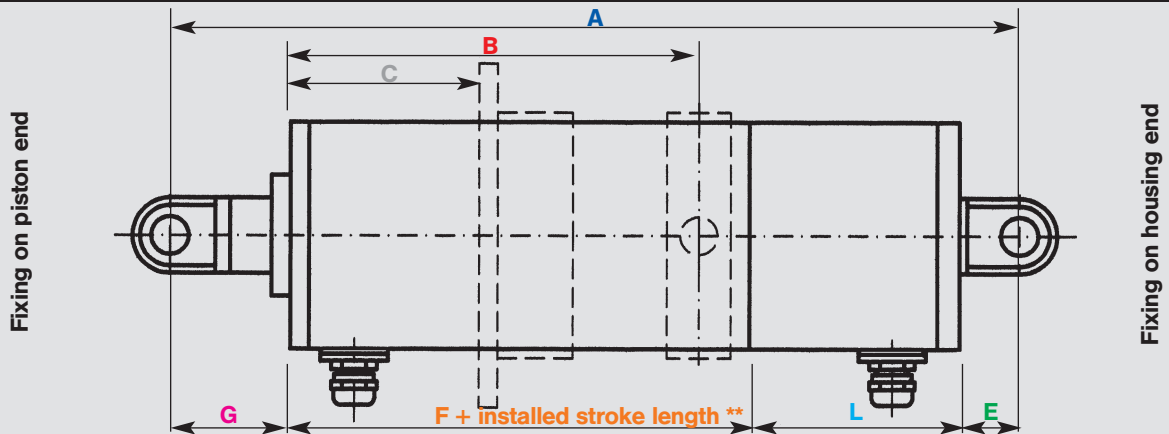

**Dimension G** Fixing on piston end

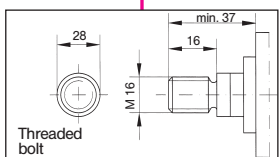
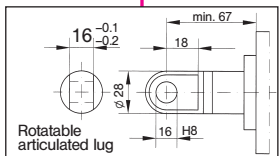
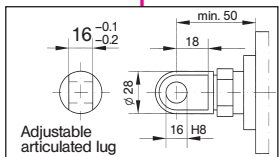
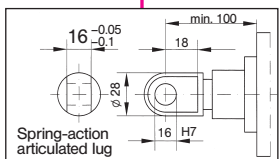
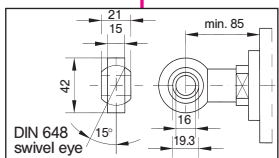
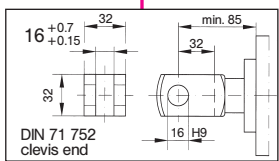
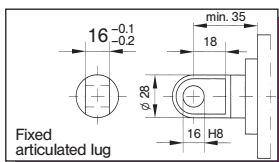

**Dimension F**

Version	Stroke lengths 50 – 450 mm	Stroke lengths 500 – 750 mm
A*	363	413 <sup>1)</sup>
B*	363	413 <sup>1)</sup>
C*	363	413 <sup>1)</sup>
D*	363	413 <sup>1)</sup>
E*	378	428 <sup>1)</sup>
F*	378	428 <sup>1)</sup>
G	303	353 <sup>1)</sup>
H	318	368 <sup>1)</sup>
I	318	368 <sup>1)</sup>
J	318	368 <sup>1)</sup>
K	318	368 <sup>1)</sup>

**Dimension A** Extension by addition of a protective sleeve

Extension	Max. utilised stroke
50 mm	0 mm - 250 mm
100 mm	> 250 mm

**Dimension L** Extension by addition of accessories

	24 V	230 / 400 V
<b>Potentiometer</b>	Ver. B/D/G/K not available	+ 75 mm
	other versions + 75 mm	
<b>Encoder</b>	Ver. B/D/G/K not available	+ 75 mm
	other versions + 75 mm	
<b>Integrated capacitor</b>	-	+ 97 mm
<b>Force limiter</b>	+ 55 mm	+ 55 mm
Extension - Please observe dimension E		

Limit switch adjustment screws

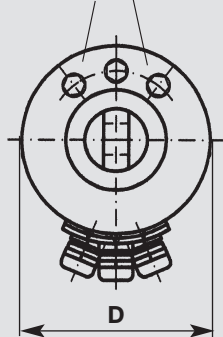

**Dimension D**

Ø 80 mm  
(housing diameter)

**Dimension B** Pivot attachment

Dimension	
<b>B</b>	> 75 mm max. = stroke
<b>V</b>	85 mm
<b>W</b>	123 mm
<b>X</b>	16 mm
<b>Y</b>	Ø 16 mm
	- 0.03 - 0.05

**Dimension E** Fixing on housing end

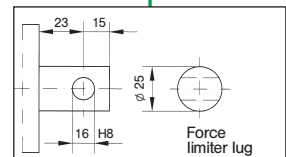
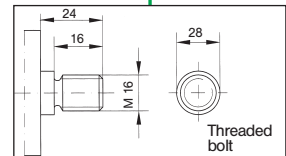
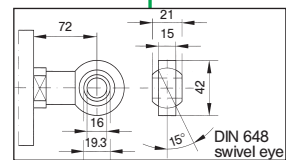
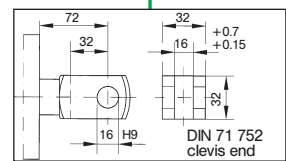
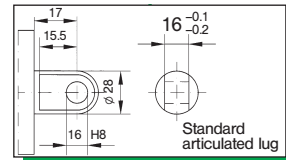

**Dimension C** Flange attachment

Dimension	
<b>C</b>	0 or > 60 mm max. = stroke
<b>P</b>	Ø 110 mm
<b>Q</b>	70 mm
<b>R</b>	Ø 6.6 mm
<b>Flange thickness</b>	5 mm

\* brake dimension (75 mm) included \*\* installed stroke length at 50 mm intervals <sup>1)</sup> including 50 mm guide extension

# Options and wiring diagrams

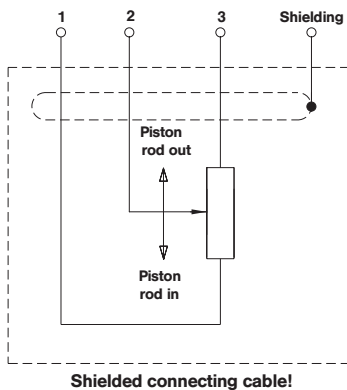

## Terminal assignment:

Signal:	0 V	+U <sub>B</sub>	A	$\bar{A}$	B	$\bar{B}$	0	$\bar{0}$
Core colour:	WH	BN	GN	YE	GY	PK	BU	RD
Without inversion:	WH	BN	GN		YE		GY	

## Electrical characteristics:

Output circuit	Rail to rail	Signal level high	min. UB -2.5 V
Supply voltage	5...24 V DC	Signal level low	max. 0.5 V
Current consumption (without load)	max. 50 mA	Rise time (t)	max. 1 ms
Admissible load / channel	max. 50 mA	Fall time (t)	max. 1 ms
Impulse frequency	max. 160 kHz	Short-circuit proof outputs	yes

CE compliance according to EN 50081-2 and EN 55011 class B.

## Wiring diagram – Potentiometer

## Terminal assignment – Encoder

## Standard wiring diagrams

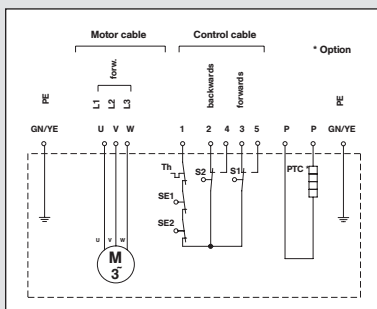

DS 0200 / 400 V 3AC

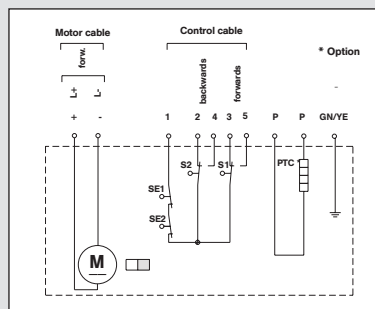

GS 0100 / 24 V DC

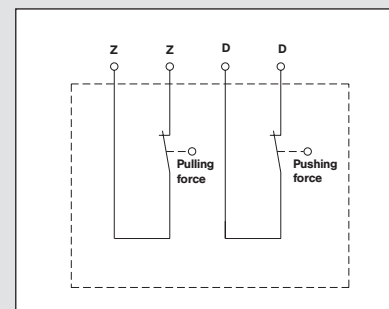

**Force limiter**

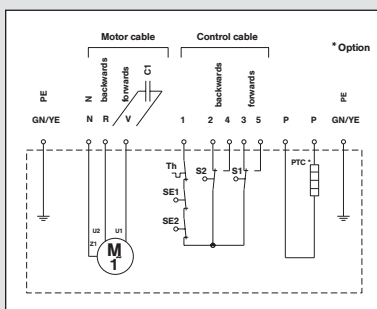

WS 0500 / 230 V 1AC

(especially for mechanical engineering)

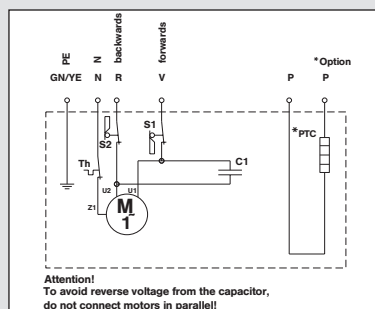

WS 0800 / 230 V 1AC

(especially for façade construction)

- Th = Thermal protection contact
- SE = Safety limit switch
- S1 = Limit switch  
Piston rod out
- S2 = Limit switch  
Piston rod in
- PTC = Heating element

## Options

(Please observe the availability notes in the table on page three)

- Standard potentiometers (1 kOhm, 5 kOhm, 10 kOhm, 100 kOhm)
- Precision potentiometers (1 kOhm, 5 kOhm, 10 kOhm)
- Encoders (especially 60 or 80 impulses per revolution)
- Internal capacitor
- Brake (supply voltages 24V DC, 230 V 1AC, 400V 1AC)
- Protective sleeve

# elero linear actuators

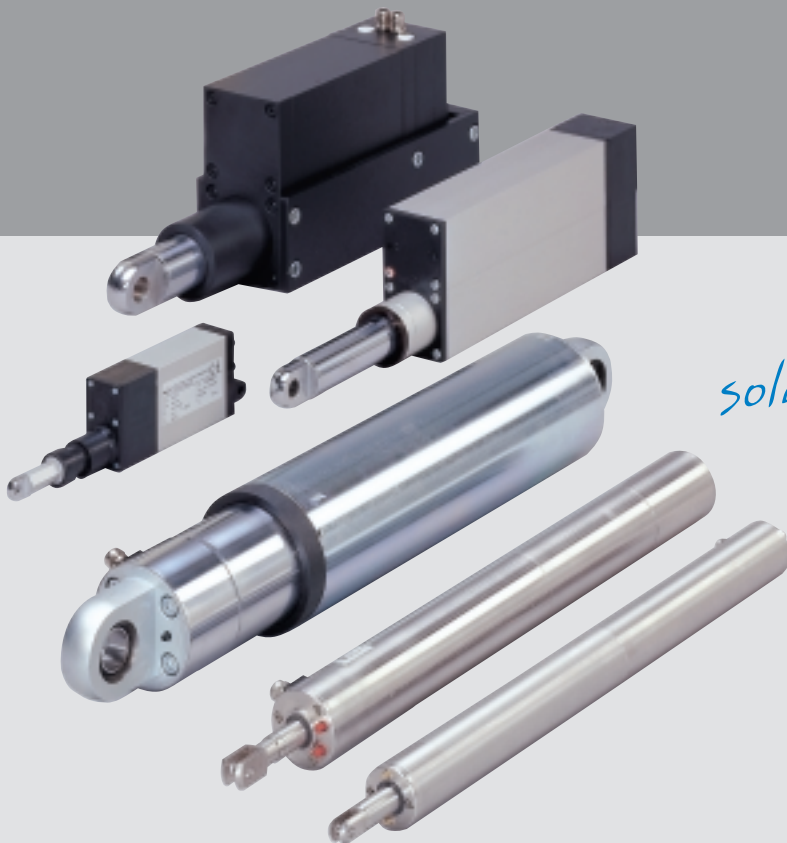

*Tailor-made  
solutions for everyone!*

Our wide product range offers powerful and high-quality solutions for an unlimited variety of applications.

Whatever you want to move – at elero you will find the linear actuator to suit your individual requirements.

Interested? Give us a call or send us a fax to receive more information.

We look forward to helping you – for at elero there is something for everyone!

## **elero GmbH**

### **Linearantriebstechnik**

Nassaeckerstrasse 11

D-07381 Poesneck

Phone +49 (0) 3647 / 46 07-0

Fax Reception +49 (0) 3647 / 46 07-40

Fax Purchasing department -41

Fax Sales department -42

Head office:

Linsenhofer Str. 59-63

D-72660 Beuren

Phone +49 (0) 70 25 / 13-02

Fax Reception +49 (0) 70 25 / 13-212

[info@elero-linear.de](mailto:info@elero-linear.de)

[www.elero-linear.com](http://www.elero-linear.com)