

Linear actuator Econom 1

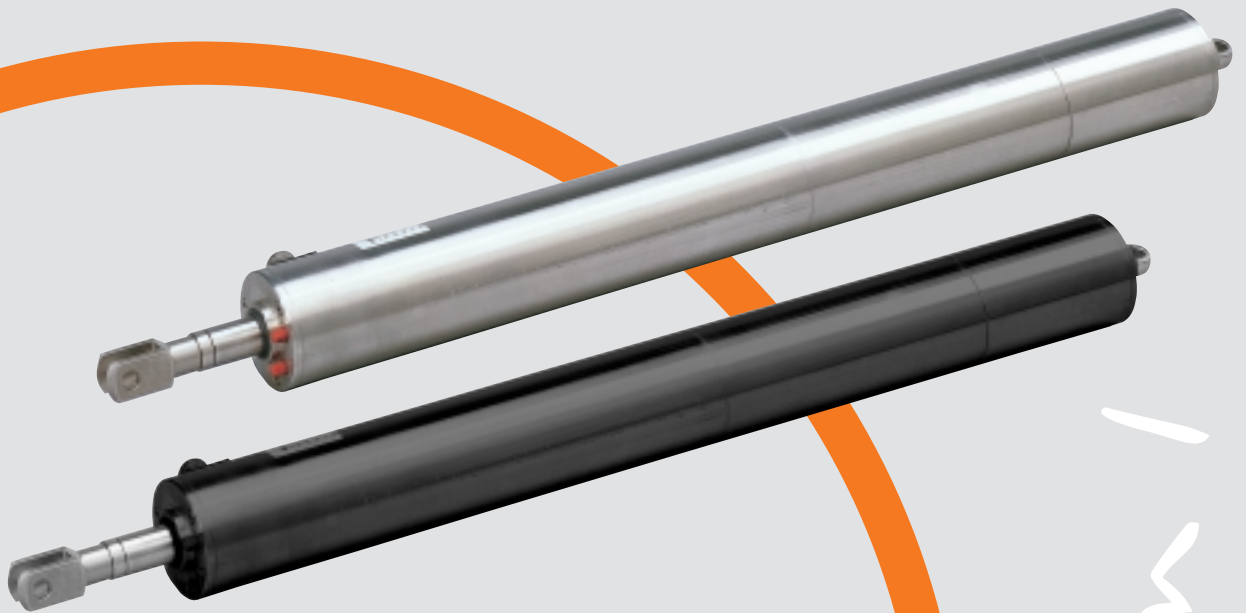

*Our intelligent model:
Econom 1*



Econom 1

Linear actuators Econom 1

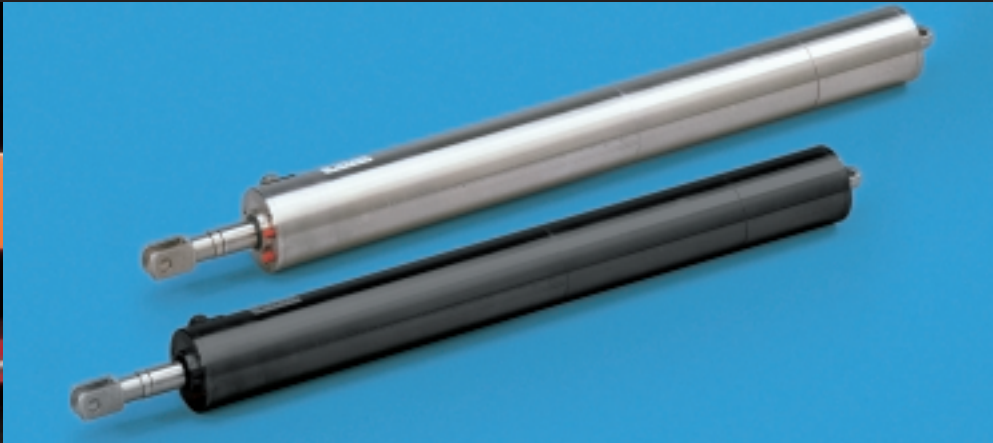

Description · Applications · Facts

The users of the Econom 1 come from many different industries: From architects and planners of contemporary façade architecture up to plant construction and mechanical engineering specialists.

Using either the steel or the stainless steel versions of the Econom 1, a wide variety of applications is possible.

Calculation example Econom 1 for dimension A

(based on the following requirements)

Pushing and pulling force	1400 N
Stroke	230 mm
Operating voltage	230 V 1 AC, rating: S3-15%
Fixing on piston end	fixed articulated lug
Fixing on housing end	standard articulated lug
Capacitor	external (standard wiring diagram WS 0500)
Option	potentiometer

Selected version:

Force	→ version B	2000 N
Dimension G	→ fixed articulated lug	35 mm
Dimension F	→ ver. B, stroke 50-450 mm	402 mm (Please observe the additional marks *, **, 1)
Inst. stroke**	→ installed stroke length	250 mm
Dimension L	→ option, potentiometer	75 mm
Dimension E	→ standard articulated lug	17 mm
Dimension A min.		779 mm

* brake dimension (75 mm) included ** installed stroke length at 50 mm intervals
1) including 50 mm guide extension

Load (N) and stroke speeds (mm/s)

Version	Stroke speed mm/s	400 V-3 AC Rating: S3 – 15%		400 V-3 AC Rating: S1		230 V-1 AC Rating: S3 – 15%		24 V DC Rating: S3 – 15%			24 V DC Rating: S1			Number of add. planetary gear stages	Available with brake only
		Load N	Nominal current A	Load N	Nominal current A	Load N	Nominal current A	V mm/s	Load N	Nom. current A	V mm/s	Load N	Nom. current A		
A	70	2000	3.5	–	–	1200	2.5	60	900	10	–	–	–	–	x
B	50	2000	3.5	–	–	2000	2.5	(40)	(1200)	10	–	–	–	–	x
C	35	2000	3.5	–	–	2000	2.5	30	1000	10	–	–	–	–	x
D	25	4000	3.5	–	–	4000	2.5	(22)	(1500)	10	–	–	–	–	x
E	14	5000	3.5	–	–	5000	2.5	12	4500	10	–	–	–	1	x
F	10	5000	3.5	–	–	5000	2.5	9	5000	10	–	–	–	1	x
G	7	5000	3.5	–	–	5000	2.5	5	5000	10	–	–	–	1	x
H	5	10000	3.0	–	–	10000	2.5	4	7500	10	–	–	–	1	–
I	3.5	10000	3.0	–	–	10000	1.8	(3)	(10000)	10	–	–	–	1	–
J	1.5	–	–	10000	0.8	10000	1.8	–	–	–	1.5	10000	5.0	2	–
K	1	–	–	10000	0.8	10000	1.5	–	–	–	1.2	10000	4.0	2	–
L	0.7	–	–	10000	0.8	10000	1.5	–	–	–	0.8	10000	3.5	2	–
M	0.5	–	–	10000	0.8	10000	1.5	–	–	–	(0.6)	(10000)	3.0	2	–

() Added surcharge for special model!

Technical data and dimensions

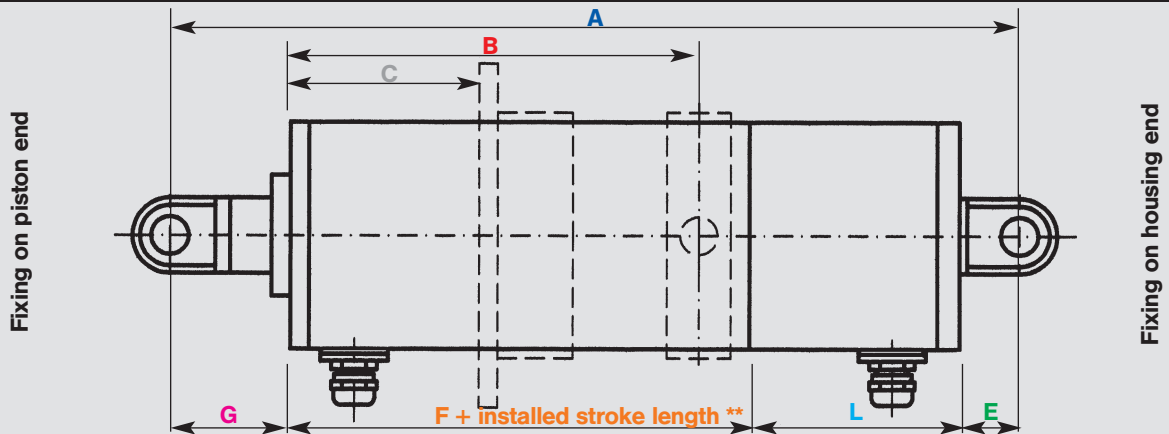

Dimension G Fixing on piston end

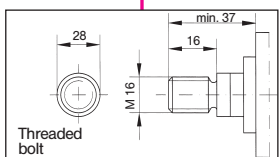
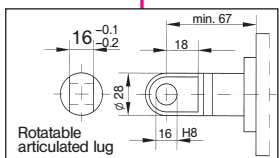
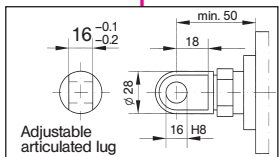
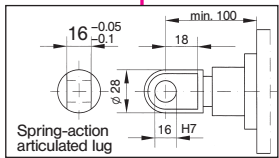
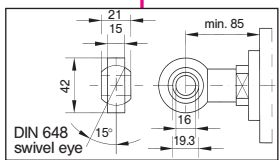
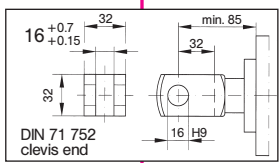
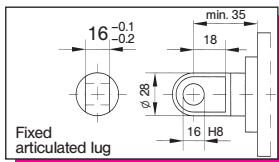

Dimension F

Version	Stroke lengths 50 – 450 mm	Stroke lengths 500 – 750 mm
A*	402	452 ¹⁾
B*	402	452 ¹⁾
C*	402	452 ¹⁾
D*	402	452 ¹⁾
E*	422	472 ¹⁾
F*	422	472 ¹⁾
G*	422	472 ¹⁾
H	397 ¹⁾	397 ¹⁾
I	397 ¹⁾	397 ¹⁾
J	417 ¹⁾	417 ¹⁾
K	417 ¹⁾	417 ¹⁾
L	417 ¹⁾	417 ¹⁾
M	417 ¹⁾	417 ¹⁾

Dimension A Extension by addition of a protective sleeve

Extension	Max. utilised stroke
50 mm	0 mm - 300 mm
100 mm	> 300 mm

Dimension L Extension by addition of accessories

	24 V	230 / 400 V
Potentiometer	Ver. B/D/I/M not available	+ 75 mm
	other versions + 75 mm	
Encoder	Ver. B/D/I/M not available	+ 75 mm
	other versions + 75 mm	
Integrated capacitor	-	+ 97 mm
Force limiter	+ 55 mm	+ 55 mm

⚠ Extension - Please observe dimension E

Limit switch adjustment screws

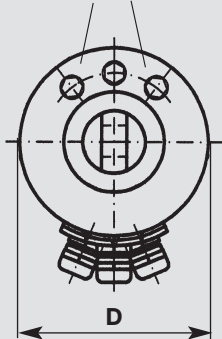

Dimension D

Ø 97 mm
(housing diameter)

Dimension B Pivot attachment

Dimension	
B	> 75 mm max. = stroke
V	105 mm
W	140 mm
X	15 mm
Y	Ø 16 mm
	- 0.03 - 0.05

Dimension E Fixing on housing end

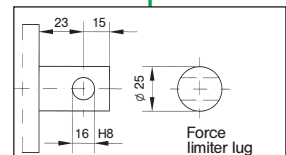
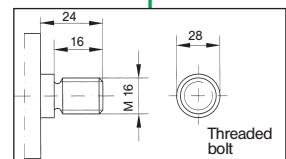
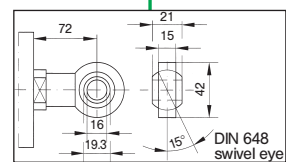
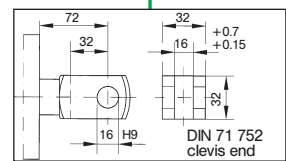
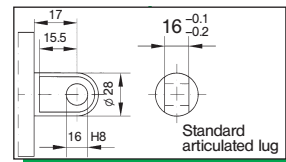

Dimension C Flange attachment

Dimension	
C	0 or > 60 mm max. = stroke
P	Ø 130 mm
Q	82 mm
R	Ø 8.6 mm
Flange thickness	6 mm

* brake dimension (75 mm) included ** installed stroke length at 50 mm intervals ¹⁾ including 50 mm guide extension

Options and wiring diagrams

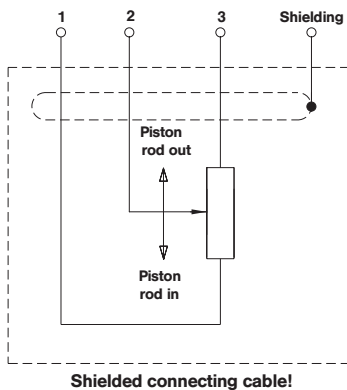

Terminal assignment:

Signal:	0 V	+U _B	A	\bar{A}	B	\bar{B}	0	$\bar{0}$
Core colour:	WH	BN	GN	YE	GY	PK	BU	RD
Without inversion:	WH	BN	GN		YE		GY	

Electrical characteristics:

Output circuit	Rail to rail	Signal level high	min. U _B -2.5 V
Supply voltage	5...24 V DC	Signal level low	max. 0.5 V
Current consumption (without load)	max. 50 mA	Rise time (t)	max. 1 ms
Admissible load / channel	max. 50 mA	Fall time (t)	max. 1 ms
Impulse frequency	max. 160 kHz	Short-circuit proof outputs	yes

CE compliance according to EN 50081-2 and EN 55011 class B.

Wiring diagram – Potentiometer

Terminal assignment – Encoder

Standard wiring diagrams

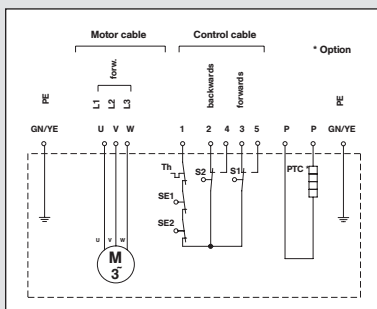

DS 0200 / 400 V 3AC

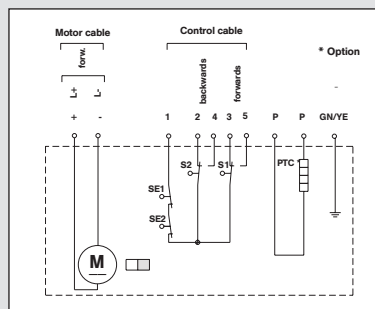

GS 0100 / 24 V DC

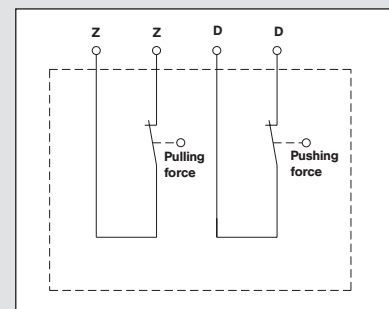

Force limiter

- Th = Thermal protection contact
- SE = Safety limit switch
- S1 = Limit switch
Piston rod out
- S2 = Limit switch
Piston rod in
- PTC = Heating element

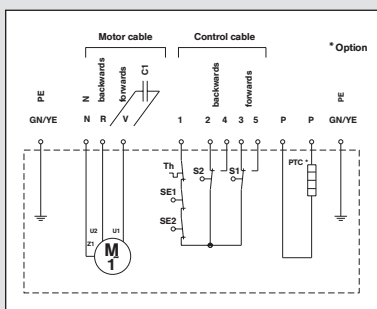

WS 0500 / 230 V 1AC

(especially for mechanical engineering)

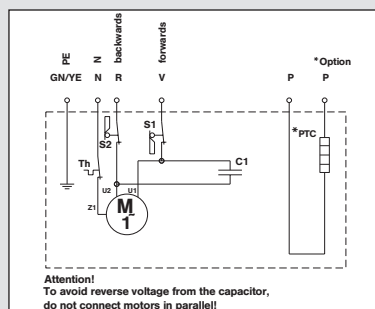

WS 0800 / 230 V 1AC

(especially for façade construction)

Options

(Please observe the availability notes in the table on page three)

- Standard potentiometers (1 kOhm, 5 kOhm, 10 kOhm, 100 kOhm)
- Precision potentiometers (1 kOhm, 5 kOhm, 10 kOhm)
- Encoders (especially 60 or 80 impulses per revolution)
- Internal capacitor
- Brake (supply voltages 24V DC, 230 V 1AC, 400V 1AC)
- Protective sleeve

elero linear actuators

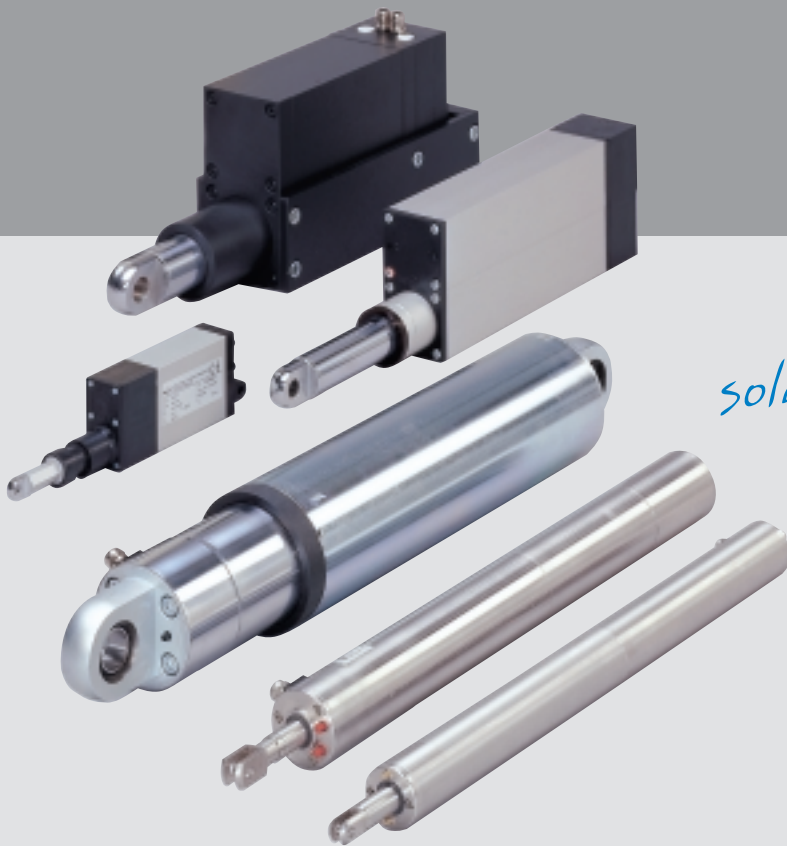

*Tailor-made
solutions for everyone!*

Our wide product range offers powerful and high-quality solutions for an unlimited variety of applications.

Whatever you want to move – at elero you will find the linear actuator to suit your individual requirements.

Interested? Give us a call or send us a fax to receive more information.

We look forward to helping you – for at elero there is something for everyone!

elero GmbH

Linearantriebstechnik

Nassaeckerstrasse 11

D-07381 Poesneck

Phone +49 (0) 3647 / 46 07-0

Fax Reception +49 (0) 3647 / 46 07-40

Fax Purchasing department -41

Fax Sales department -42

Head office:

Linsenhofer Str. 59-63

D-72660 Beuren

Phone +49 (0) 70 25 / 13-02

Fax Reception +49 (0) 70 25 / 13-212

info@elero-linear.de

www.elero-linear.com