

Stainlesssteel IEC B14 motors

Features

- 1) 300 Series Stainless Steel Construction.
- 2) Inverter duty
- 3) Washdown Duty Applications.
- 4) BISSC Certified.
- 5) Corrosion Resistant.
- 6) Laser Etched Nameplate.
- 7) Oversized Bearings on both ends
c/w Locked Drive-end Bearing
Construction.
- 8) Oversized Conduit Box c/w Lead
Seal.
- 9) Drill & Tapped Drains.
- 10) T-Drain included.
- 11) Double Lip Contact Seals.

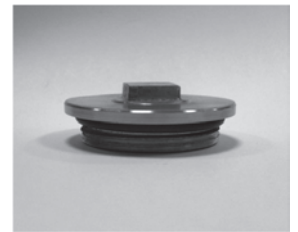
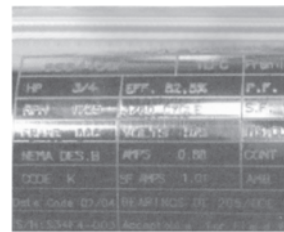
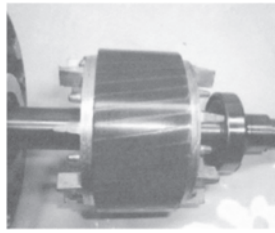

B14

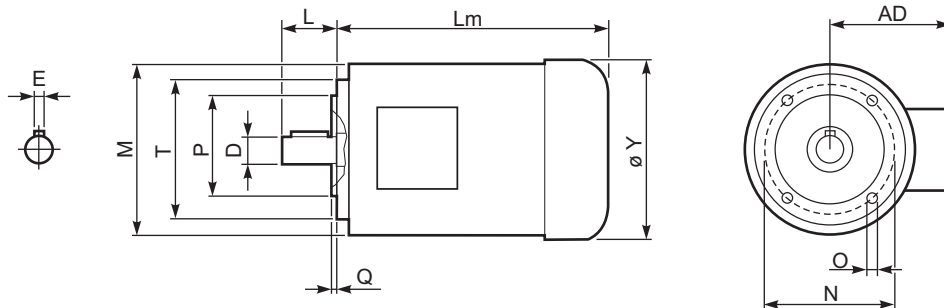

Outside dimensions may be different according to manufacturers.

Le dimensioni esterne sono indicative, possono variare tra i vari costruttori.

	4 poli / poles			D	E	L	Lm	Y	AD	P	N	M	T	O	Q	Kg
	kW	Nm	A (400V)													
63	0.18	1.30	0.69	11	4	23.5	252	128	106	60	75	114	90	M5	2.5	8.2
71	0.25	1.70	0.91	14	5	30.5	228	146	115	70	85	134	105	M6	2.5	8.3
	0.37	2.52	1.14				252									10.4
80	0.55	3.77	1.51	19	6	40	300	158	115	80	100	144	120	M6	3	17.5
	0.75	5.11	2.57				300									
90	1.1	7.45	2.78	24	8	50	321	174	135	95	115	165	140	M8	3	22.4
	1.5	10.2	3.61				367									27.6
100	2.2	14.8	5.07	28	8	60	374	203	150	110	130	190	160	M8	3.5	33.5

Tecnical data
- Voltage: 230 / 400V
- Phase: 3
- Frequency: 50Hz
- Poles: 4
- International protections : IP 65
- Insulation class: F
- Duty: S1